

# **USER MANUAL**

# **CIRCLE FLAMER**

# **X-F3600**

V3.1

2024/06





## ▲ Foreword

Thanks for choosing SHOWVEN CIRCLE FLAMER X-F3600, we wish it will bring you lots of exciting moments. Please read the following manual carefully before operating this product. Operate according to instructions is very important for safety, and can elongate the service life of the machine

Strictly follow the instruction in the manual when operate CIRCLE FLAMER X-F3600. If you have any doubts, please contact SHOWVEN technologies Co., Ltd by info@showven.cn

We assume the person who use or come in contact with the device are familiar with how the device should be handled. This includes proper use, maintenance and repair of the machine as defined in this user manual.

## ▲ Warning

- ⚠ This product is only suitable for qualified or skilled operators who has experience with the technology of the device and is particularly informed about the types of fuel used by the device.
- ⚠ Unauthorized repair are prohibited, it may cause serious incident
- ⚠ Make sure power supply in consistent with the rated voltage of the equipment, and the socket must well grounded. Unplug and turn off the machine when not use
- ⚠ Before connect the power cable, communication DMX cable should well connected and ensure the command keep at firing OFF status. And safety switch on CIRCLE FLAMER X-F3600 stay at TEST MODE.
- ⚠ Before power on the machine, please check carefully the safety distance and make sure it meets the requirements in this manual.
- ⚠ The device can only be placed horizontally.
- ⚠ After turning on the device, no person allows to stay in the danger area. Ensure all persons that are part of the show be informed about the safety distance, risks and functions of the device
- ⚠ Always have a CO<sub>2</sub> fire extinguisher and an extinguishing blanket in case of needed
- ⚠ If there be any doubt as to the safety operation of the device in any circumstances, the device should be taken out of service immediately. Be sure the device is in good operating condition before use. If fail to fire correctly, immediately shut down and check it accordingly
- ⚠ Be sure to use high quality flame fluid, otherwise, it is easily leads to failure or danger. Be careful when refill the flame fluid tank. Please keep flame fluid away from heat source, sparks, fire or other possibility of ignition. Do not smoke!
- ⚠ The operator responsible for the control of Circle Flamer must always have a clear view of the device, so that he/she can stop the show immediately when there is danger. The main AC power switch should near operator. So that operator can turn off the power of all devices in case of abnormal.
- ⚠ Do remember to remove the firing head protection cover before before power on the machine.
- ⚠ When X-F3600 is powered off, manually rotate the flame-throwing head over  $\pm 90^\circ$  is strictly forbidden to, otherwise the rotating mechanism of the equipment will be damaged.
- ⚠ The device shall not be altered and applied to other use purpose.

## ▲ Disclaimers:

SHOWVEN technologies Co., Ltd excludes liability for unsafe situations, accidents and damages resulting from:

1. Ignoring warnings or regulations as shown on circle flamer or this manual
2. Use for other applications or circumstances other than those indicated herein
3. Changes to the circle flamer, including use of non-original spare parts
4. Removed safety cover without authorization from SHOWVEN.
5. Use this machine by unqualified or untrained personnel.
6. Improper use of machine.

## ▲ Functional Characteristics

- ✓ Original innovation introduced by SHOWVEN
- ✓ Full cycle and half cycle mode switchable
- ✓ Up to 182 preset firing sequences
- ✓ Nozzle front design, safer for operator
- ✓ Stainless steel nozzle, reliable and durable
- ✓ Safety lock with switchable test mode
- ✓ Double electromagnetic valves design for additional safety
- ✓ Double pump ensure stable pressure
- ✓ Fitted with igniter signal interface, compatible with fireworks firing system
- ✓ Neutrik® powerCON TRUE1 in/out, Neutrik® 3-pin & 5-pin DMX in/out, 9-60V pyro signal port.

## ▲ Technical Specifications

- ✓ **MODEL:** X-F3600
- ✓ **ROTATION MODE:** FULL CIRCLE MODE / HALF CIRCLE MODE
- ✓ **DIMENSION:** 640×360×370mm
- ✓ **WEIGHT:** 30kg
- ✓ **VOLTAGE:** AC100-120V or AC200-240V, 50/60Hz
- ✓ **POWER:** 380W
- ✓ **USAGE IN RAIN:** YES
- ✓ **CONTROL:** DMX, 9-60V pyro signal
- ✓ **INTERFACE:** Neutrik® powerCON TRUE1 IN/OUT  
Neutrik® 3-pin& 5-pin XLR IN/OUT  
9V-60V Fireworks igniter signal port
- ✓ **FLAME HEIGHT:** up to 8-10m (no wind)
- ✓ **ROTATE ANGLES:** 1080° (up to 3 cycles)
- ✓ **FUEL:** ISOPAR-G, H, L, M; ISOPROPANEL
- ✓ **FUEL TANK CAPACITY:** 10L
- ✓ **FUEL CONSUMPTION RATE:** 60ml/s(M), 30ml/s(L), 15ml/s(EL)
- ✓ **EXT. BATTERY POWERED:** YES
- ✓ **Stereo Stand Hole:** Yes, (φ36mm, depth 88mm)

## ▲ Structure of Circle Flamer

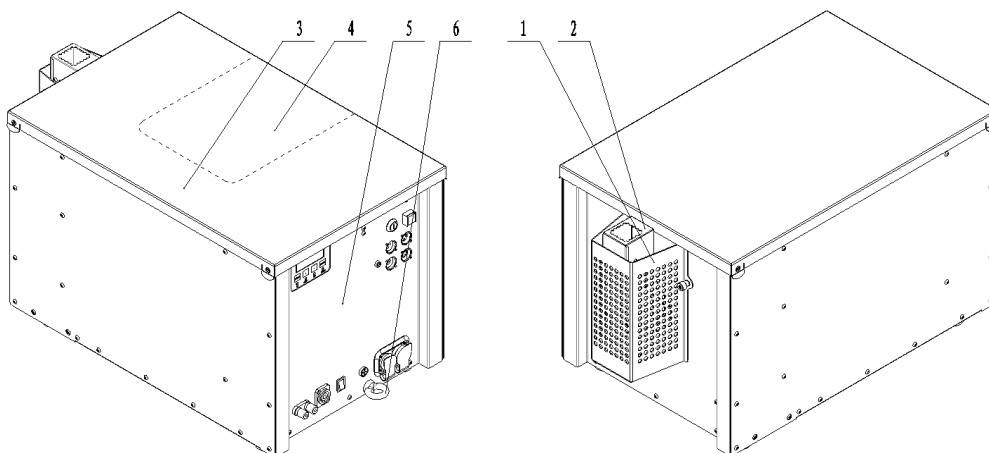

1. Firing Head Protection Cover  
4. Fuel Bottle Area

2. Firing Head  
5. Control Panel

3. Top Panel  
6. Safety Loop

### Diagram of bottom panel

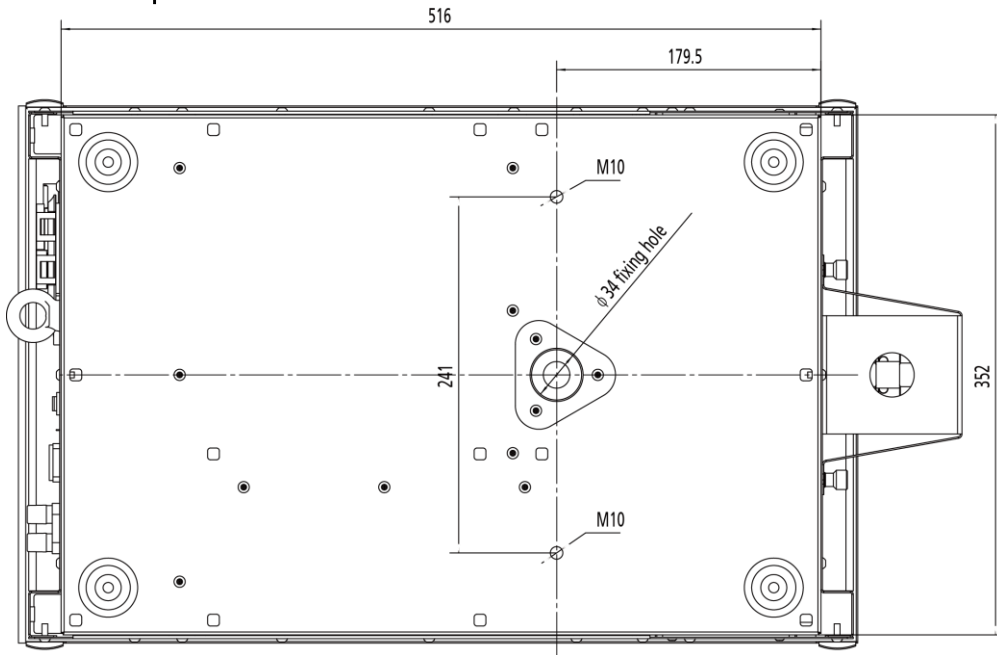

### Rear Panel

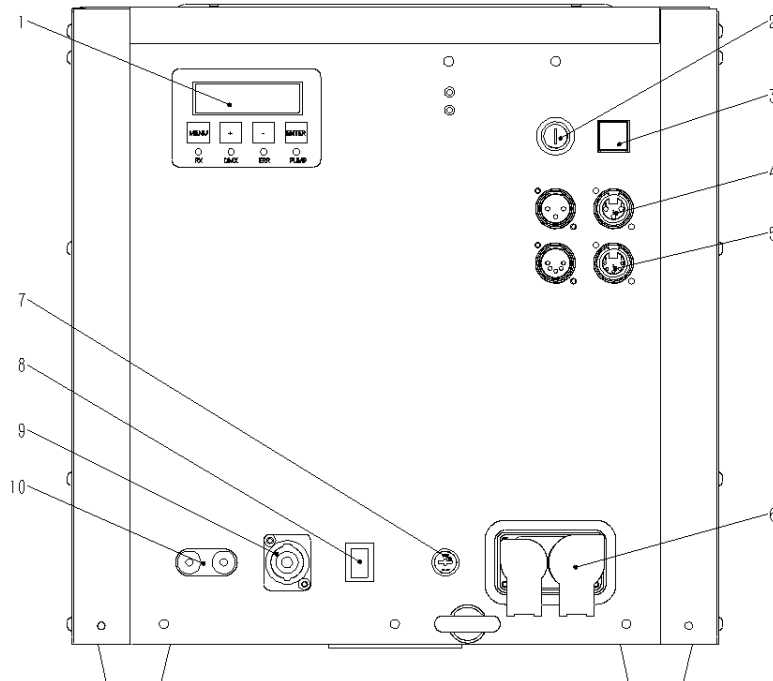

- |  |                                |                          |
|--|--------------------------------|--------------------------|
| 1. LCD screen operate panel  | 2. Safety Lock                 | 3. Indicator Light (red) |
| 4. 3-pin DMX IN/OUT  | 5. 5-pin DMX IN/OUT            |                          |
| (5-PIN XLR IN can charge for wireless DMX pen through pin1 and 4, pin4 with DC5V power supply) |                                |                          |
| 6. Power IN/OUT  | 7. Fuse                        | 8. ON/OFF switch         |
| 9. 12V Battery Power Input   | 10. DC 9V-60V pyro signal port |                          |

## ▲ Operation Panel

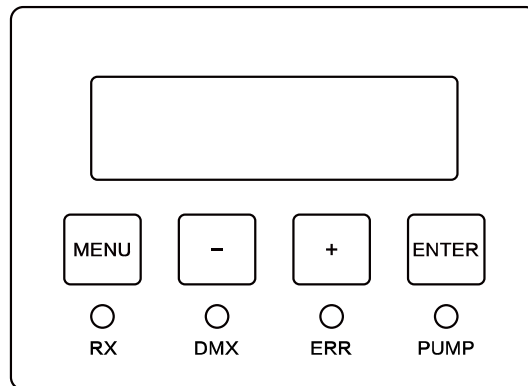

### 1. LED Display Area:

**RX:** Radio receiving (reserved)

**DMX:** DMX signal. Flash means DMX signal available, otherwise no DMX signal

**ERR:** Light on when there is an error

**PUMP:** Light on when pump is running

### 2. Button Functions:

**MENU:** Switch interface to setup parameter;

**+:** Parameter Up

**-:** Parameter Down

**ENTER:** Confirm and save parameters (screen will flash when parameters saved)

*Note: screen display will switch to main interface if not press button in 10s.*

### 3. Welcome Interface:



**First Line:** Product model and software version

**Second Line:** Equipment series number

### 4. Main Interface:

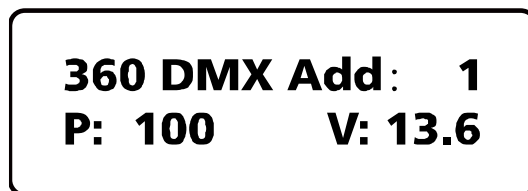

**First Line:** Rotation Mode (360=Full Cycle Mode or 180=Half Cycle Mode ); DMX address;

**Second Line:** "P: 100" means Pressure100 (100=10bar); "V: 13.6" means internal voltage is 13.6V;

### 5. Alert Message:

Alert Message	Why it appears	How to remove
E0 Test Mode	Safety Switch at TEST MODE	Switch to USER MODE
E0 Factory Mode	Factory mode	Switch to Normal mode
E0 Invert On	Invert function ON	Set Invert to OFF
E0 FireForbidden	Fire Forbidden ON	Set Fire Forbidden to OFF
E0 ExtIgnite ON	Ext Ignite ON	Set Ext Ignite to OFF

### 6. Error Message

Error Message	Why it appears	Reason / How to remove
E1 Pressure Err	Pressurize for 8s, if pressure value failed to reach target value	No fuel, pump failure, pipeline fuel leakage etc reason, please check accordingly
E2 P Relief Err	Depressurize for 2.5s, if pressure value $\geq 50\%$ of target value	Pressure release valve failure
E5 Voltage Err	DC input < 10V or > 15v	Make sure DC input between 10-15V
E6 Tip Err	Machine slant over 45°	Tip setting set to OFF, or horizontal install machine.

### 7. Interface setup:

Press "MENU" to switch through setup menu

Menu	Range	Explanation
Set DMX Address	1~512	DMX address setup
Set Rotation Mode	Full Cycle Mode(360)/ Half Cycle Mode(180)	Cycle Mode Switch
Angle Limit*	Maxi. ANGLE : NO.1 - NO.15	Restrict nozzle rotate angles: Set by "+" and "-", and confirm by "ENTER"
	Mini. ANGLE : NO.1 - NO.15	
Limit Test	OFF / ON	Test the angle limit function after setting angle limit.

\* Activate only under Half Cycle Mode (180)

#### Steps setting the angle limit and install angle blocks. (only for Half Cycle Mode)

- Set the "Maxi. Angle" and "Mini. Angle", press "ENTER" to save the changes.
- Running the Limit Test by set it to ON, and press ENTER, nozzle will move from Mini. Angle to Maxi. Angle, then to the middle.
- After confirm the software angle limit control works well, then put angle limit rod at corresponding Mini. Angle and Maxi. Angle. Running Limit test again to reconfirm the angle limit rod was correctly installed.

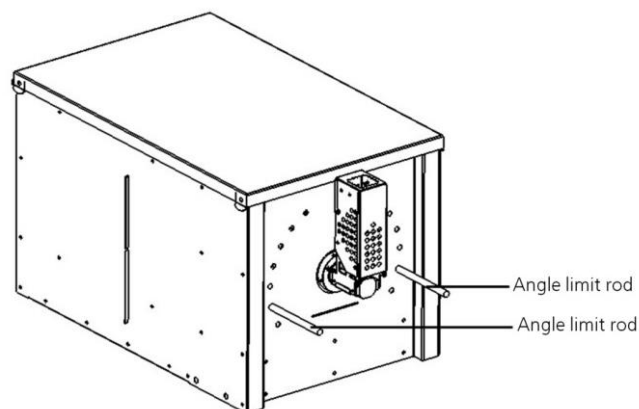

### 8. Advanced Interface:

Press "MENU" 3s enter advanced interface, press "MENU" to switch interface, press "MENU" 3s can back to main interface. The value in bold character is default value.

Items	Contents	Description
Drive Test	Motor	Swiveling and stop at target angle.
	Pump	Pump running, if pressure reached the target value, the pump will not running.
	Igniter	Ignite 1s
	Relief Valve	Relief valve on and off 3 times
	Jet Valve 1	Safety lock located at USER MODE, pressure relief valve on, then related jet valve on and off 3 times.
	Jet Valve 2	
Ext Ignite	OFF / ON	Trigger through 9-60V Pyro igniter signal
Set Ext Sequence	Full Cycle Mode: 1~94 Half Cycle Mode: 1~88	Preset sequence triggered by pyro signal
Language	English / Chinese	Language switch
Mode Select	Normal Mode / Factory Mode	Factory mode is for test in factory only
Tip Setting	ON / OFF	Turn ON/OFF tip over function
Head to middle	OFF / ON	Channel 1=0, Firing head will remain in middle position (M2 or NO.8) after running a preset sequence.
Invert	OFF / ON	When turned on, all angles will be mirrored.
Motor Disabled	OFF / ON	When turned on, the position of the firing head should be moved or set manually, and the motor of firing head will be disabled. (The flamer should be restarted before it takes effect.)
Default Parameter	OFF / ON	Reset default parameter settings

## ▲ Full Cycle Mode

### 1. Firing Angles:

CIRCLE FLAMER X-F3600 with 360° firing angles, below schematic shows firing angles from Audience Side view. 1080° (360°X3) is divided into 72 projection directions, the angle NO. as below:

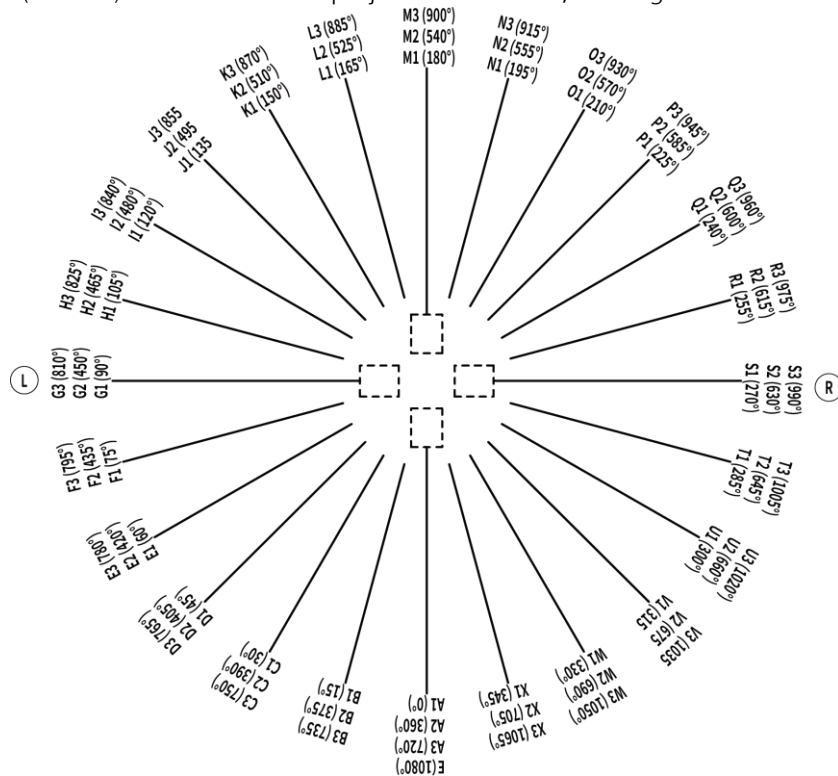



## 2. Drive time for effects

It takes 20ms to reach the adjacent firing angle. For example, the time required for the nozzle to reach NO.B1 from NO.A1 is 20ms. This time needs to be considered when programming a show. The table below shows the time it takes for the nozzle to reach the desired angle from NO.A1.

No.	Angles	Drive time needed
NO.A1	0°	0ms
NO.B1	15°	20ms
NO.C1	30°	40ms
NO.D1	45°	60ms
NO.E1	60°	80ms
NO.F1	75°	100ms
NO.G1	90°	120ms
NO.H1	105°	140ms
NO.I1	120°	160ms
NO.J1	135°	180ms
NO.K1	150°	200ms
NO.L1	165°	220ms
NO.M1	180°	240ms
NO.N1	195°	260ms
NO.O1	210°	280ms
NO.P1	225°	300ms
NO.Q1	240°	320ms
NO.R1	255°	340ms
NO.S1	270°	360ms
NO.T1	285°	380ms
NO.U1	300°	400ms
NO.V1	315°	420ms
NO.W1	330°	440ms
NO.X1	345°	460ms
NO.A2	360°	480ms
NO.B2	375°	500ms
NO.C2	390°	520ms
NO.D2	405°	540ms
NO.E2	420°	560ms
...	...	...
NO.A3	720°	960ms
...	...	...
E(END)	1080°	1440ms

## 3. Sequence list:

Circle Flamer X-F3600 with more than 182 kind of preset firing sequences, 94 kind of firing sequences under full cycle mode. Operator use related channel DMX value or sequence No. to access certain sequence. Sequence list as below:

### Single Ignition Sequence List

No.	Ignition angle NO.	Ignition angle	Description	Single shot duration	Sequence Duration	CH5 DMX Value
1	A2	0°	Single ignition SHORT flame	0.04s	0.19s	3-5

2	B2	15°	Single ignition SHORT flame	0.04s	0.19s	6-7
3	C2	30°	Single ignition SHORT flame	0.04s	0.19s	8-10
4	D2	45°	Single ignition SHORT flame	0.04s	0.19s	11-12
5	E2	60°	Single ignition SHORT flame	0.04s	0.19s	13-15
6	F2	75°	Single ignition SHORT flame	0.04s	0.19s	16-17
7	G2	90°	Single ignition SHORT flame	0.04s	0.19s	18-20
8	H2	105°	Single ignition SHORT flame	0.04s	0.19s	21-22
9	I2	120°	Single ignition SHORT flame	0.04s	0.19s	23-25
10	J2	135°	Single ignition SHORT flame	0.04s	0.19s	26-28
11	K2	150°	Single ignition SHORT flame	0.04s	0.19s	29-30
12	L2	165°	Single ignition SHORT flame	0.04s	0.19s	31-33
13	M2	180°	Single ignition SHORT flame	0.04s	0.19s	34-35
14	N2	195°	Single ignition SHORT flame	0.04s	0.19s	36-38
15	O2	210°	Single ignition SHORT flame	0.04s	0.19s	39-40
16	P2	225°	Single ignition SHORT flame	0.04s	0.19s	41-43
17	Q2	240°	Single ignition SHORT flame	0.04s	0.19s	44-45
18	R2	255°	Single ignition SHORT flame	0.04s	0.19s	46-48
19	S2	270°	Single ignition SHORT flame	0.04s	0.19s	49-50
20	T2	285°	Single ignition SHORT flame	0.04s	0.19s	51-53
21	U2	300°	Single ignition SHORT flame	0.04s	0.19s	54-56
22	V2	315°	Single ignition SHORT flame	0.04s	0.19s	57-58
23	W2	330°	Single ignition SHORT flame	0.04s	0.19s	59-61
24	X2	345°	Single ignition SHORT flame	0.04s	0.19s	62-63
25	A2	0°	Single ignition LONG flame	0.34s	0.56s	64-66
26	B2	15°	Single ignition LONG flame	0.34s	0.56s	67-68
27	C2	30°	Single ignition LONG flame	0.34s	0.56s	69-71
28	D2	45°	Single ignition LONG flame	0.34s	0.56s	72-73
29	E2	60°	Single ignition LONG flame	0.34s	0.56s	74-76
30	F2	75°	Single ignition LONG flame	0.34s	0.56s	77-79
31	G2	90°	Single ignition LONG flame	0.34s	0.56s	80-81
32	H2	105°	Single ignition LONG flame	0.34s	0.56s	82-84
33	I2	120°	Single ignition LONG flame	0.34s	0.56s	85-86
34	J2	135°	Single ignition LONG flame	0.34s	0.56s	87-89
35	K2	150°	Single ignition LONG flame	0.34s	0.56s	90-91
36	L2	165°	Single ignition LONG flame	0.34s	0.56s	92-94
37	M2	180°	Single ignition LONG flame	0.34s	0.56s	95-96
38	N2	195°	Single ignition LONG flame	0.34s	0.56s	97-99
39	O2	210°	Single ignition LONG flame	0.34s	0.56s	100-101
40	P2	225°	Single ignition LONG flame	0.34s	0.56s	102-104
41	Q2	240°	Single ignition LONG flame	0.34s	0.56s	105-107
42	R2	255°	Single ignition LONG flame	0.34s	0.56s	106-110
43	S2	270°	Single ignition LONG flame	0.34s	0.56s	111-112
44	T2	285°	Single ignition LONG flame	0.34s	0.56s	113-114
45	U2	300°	Single ignition LONG flame	0.34s	0.56s	115-117
46	V2	315°	Single ignition LONG flame	0.34s	0.56s	118-119
47	W2	330°	Single ignition LONG flame	0.34s	0.56s	120-121
48	X2	345°	Single ignition LONG flame	0.34s	0.56s	122-124

**Step Sequences List:**

No	Ignition angle NO.	Description	Nozzle movement	Sequence Duration	CH5 DMX Value
49	Step from M2-M3	30°-SHORT flame Step sequence	Clockwise	2.40s	125-127
50	Step from M2-M1	30°-SHORT flame Step sequence	Anticlockwise	2.40s	128-130
51	Step from M2-M3	45°-SHORT flame Step sequence	Clockwise	1.70s	131-132
52	Step from M2-M1	45°-SHORT flame Step sequence	Anticlockwise	1.70s	133-135
53	Step from M2-A3	30°-SHORT flame Step sequence	Clockwise	3.40s	136-137
54	Step from M2-A1	30°-SHORT flame Step sequence	Anticlockwise	3.40s	138-140
55	Step from M2-A3	45°-SHORT flame Step sequence	Clockwise	2.4s	141-142
56	Step from M2-A1	45°-SHORT flame Step sequence	Anticlockwise	2.4s	143-145
57	Step from A1-E	30°-SHORT flame Step sequence	Clockwise	7.50s	146-147
58	Step from E-A1	30°-SHORT flame Step sequence	Anticlockwise	7.50s	148-150
59	Step from A1-E	45°-SHORT flame Step sequence	Clockwise	5.4s	151-152
60	Step from E-A1	45°-SHORT flame Step sequence	Anticlockwise	5.4s	153-155
61	Step from A1-E	Accelerate-3 cycles - SHORT flame	Clockwise	8.9s	156-158
62	Step from E-A1	Accelerate-3 cycles - SHORT flame	Anticlockwise	8.9s	159-160
63	Step from A1-E	Decelerate-3 cycles - SHORT flame	Clockwise	8.9s	161-163
64	Step from E-A1	Decelerate-3 cycles - SHORT flame	Anticlockwise	8.9s	164-165
65	Step from M2<>M3	Back and forth-4cycles-SHORT flame	C>AC>C>AC	5.9s	166-168
66	Step from M2<>M1	Back and forth-4cycles-SHORT flame	AC>C>AC>C	5.9s	169-170

**Wave Sequence List:**

No.	Ignition angle NO.	Description	Nozzle movement	Sequence Duration	CH5 DMX Value
67	Wave M2-->M3	Clover shape wave-1cycle sequence	Clockwise	2.3s	171-173
68	Wave M2-->M1	Clover shape wave-1cycle sequence	Anticlockwise	2.3s	174-175
69	Wave M2-->M3	Fast-1cycle sequence	Clockwise	0.8s	176-178
70	Wave M2-->M1	Fast-1cycle sequence	Anticlockwise	0.8s	179-181
71	Wave M2-->M3	Slow-1cycle sequence	Clockwise	1.76s	182-183
72	Wave M2-->M1	Slow-1cycle sequence	Anticlockwise	1.76s	184-186
73	Wave M2-->A3	Fast-1.5cycle sequence	Clockwise	1.17s	187-188
74	Wave M2-->A1	Fast-1.5cycle sequence	Anticlockwise	1.17s	189-191
75	Wave M2-->A3	Slow-1.5cycle sequence	Clockwise	1.8s	192-193
76	Wave M2-->A1	Slow-1.5cycle sequence	Anticlockwise	1.8s	194-196

77	Wave A1-->E	Fast-3cycle sequence	Clockwise	3.1s	197-198
78	Wave E-->A1	Fast-3cycle sequence	Anticlockwise	3.1s	199-201

**Additional Sequences List:**

No	Ignition angle NO.	Description	Nozzle movement	Sequence Duration	CH5 DMX Value
79	Step from F2-T2	15°- SHORT flame Step sequence	L->R	2.6s	202-203
80	Step from T2-F2	15°- SHORT flame Step sequence	R->L	2.6s	204-206
81	Step I2-K2-M2-O2-Q2	30°- SHORT flame Step sequence	L->R	1.26s	207-209
82	Step Q2-O2-M2-K2-I2	30°- SHORT flame Step sequence	R->L	1.26s	210-211
83	Step J2-M2-Q2	45°- SHORT flame Step sequence	L->R	0.95s	212-214
84	Step Q2-M2-J2	45°- SHORT flame Step sequence	R->L	0.95s	215-216
85	Step K2-O2	60°- SHORT flame Step sequence	L->R	0.78s	217-219
86	Step O2-K2	60°- SHORT flame Step sequence	R->L	0.78s	220-221
87	Wave J2-->P2	Middle wave sequence	L->R	2.25s	222-224
88	Wave P2-->J2	Middle wave sequence	R->L	2.25s	225-226
89	Wave F2-->M2	SHORT wave sequence	L->M	2.4s	227-229
90	Wave T2-->M2	SHORT wave sequence	R->M	2.4s	230-232
91	Wave F2-->T2	LONG wave sequence	L->R	4.3s	233-234
92	Wave T2-->F2	LONG wave sequence	R->L	4.3s	235-237
93	Step from I2<>Q2	30°- SHORT flame Step sequence	L->R->L->R->L	3.9s	238-239
94	Step from Q2<>I2	30°- SHORT flame Step sequence	R->L->R->L->R	3.9s	240-242

**▲ Half Cycle Mode**

**1. Firing Angles:**

In half cycle mode, CIRCLE FLAMER X-F3600 with firing angle of  $\pm 105^\circ$ , below schematic shows firing angles from Audience Side view.  $\pm 105^\circ$  is divided into 15 firing directions as below:

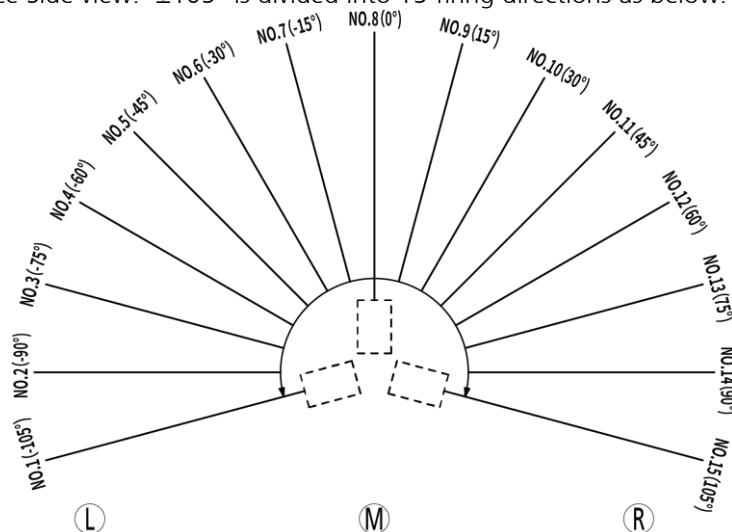

## 2. Drive time for Effects:

Time needed for the motor drive from NO.8 to relevant angle.

No.	Angles	Drive time needed
NO.1	-105°	170ms
NO.2	-90°	150ms
NO.3	-75°	130ms
NO.4	-60°	110ms
NO.5	-45°	90ms
NO.6	-30°	70ms
NO.7	-15°	50ms
NO.8	0°	0ms
NO.9	15°	50ms
NO.10	30°	70ms
NO.11	45°	90ms
NO.12	60°	110ms
NO.13	75°	130ms
NO.14	90°	150ms
NO.15	105°	170ms

For example for the motor drive from 0° to 45°, it need 90ms, when operator design a show to synchronize to music, this drive time must be calculated.

## 3. Sequences list:

Circle Flamer X-F3600 with more than 182 kind of preset firing sequences, 88 kind of firing sequences under half cycle mode. Operator use related channel DMX value or sequence No. to access certain sequence. Sequence list as below:

### Single Ignition Sequence List

No.	Ignition angle	Description	Single shot duration	Sequence Duration	CH5 DMX Value
1	-105°	Single Ignition SHORT flame	0.04s	0.19s	3-5
2	-90°	Single Ignition SHORT flame	0.04s	0.19s	6-7
3	-75°	Single Ignition SHORT flame	0.04s	0.19s	8-10
4	-60°	Single Ignition SHORT flame	0.04s	0.19s	11-12
5	-45°	Single Ignition SHORT flame	0.04s	0.19s	13-15
6	-30°	Single Ignition SHORT flame	0.04s	0.19s	16-17
7	-15°	Single Ignition SHORT flame	0.04s	0.19s	18-20
8	0°	Single Ignition SHORT flame	0.04s	0.19s	21-22
9	15°	Single Ignition SHORT flame	0.04s	0.19s	23-25
10	30°	Single Ignition SHORT flame	0.04s	0.19s	26-28
11	45°	Single Ignition SHORT flame	0.04s	0.19s	29-30
12	60°	Single Ignition SHORT flame	0.04s	0.19s	31-33
13	75°	Single Ignition SHORT flame	0.04s	0.19s	34-35
14	90°	Single Ignition SHORT flame	0.04s	0.19s	36-38
15	105°	Single Ignition SHORT flame	0.04s	0.19s	39-40
16	-105°	Single Ignition LONG flame	0.34s	0.56s	41-43
17	-90°	Single Ignition LONG flame	0.34s	0.56s	44-45
18	-75°	Single Ignition LONG flame	0.34s	0.56s	46-48
19	-60°	Single Ignition LONG flame	0.34s	0.56s	49-50
20	-45°	Single Ignition LONG flame	0.34s	0.56s	51-53

21	-30°	Single Ignition LONG flame	0.34s	0.56s	54-56
22	-15°	Single Ignition LONG flame	0.34s	0.56s	57-58
23	0°	Single Ignition LONG flame	0.34s	0.56s	59-61
24	15°	Single Ignition LONG flame	0.34s	0.56s	62-63
25	30°	Single Ignition LONG flame	0.34s	0.56s	64-66
26	45°	Single Ignition LONG flame	0.34s	0.56s	67-68
27	60°	Single Ignition LONG flame	0.34s	0.56s	69-71
28	75°	Single Ignition LONG flame	0.34s	0.56s	72-73
29	90°	Single Ignition LONG flame	0.34s	0.56s	74-76
30	105°	Single Ignition LONG flame	0.34s	0.56s	77-79

### Step Sequences List

No.	Ignition angle NO.	Description	Nozzle movement	Sequence Duration	CH5 DMX Value
31	Step from 1-15	SHORT flame Step sequence	L -> R	2.66s	80-81
32	Step from 15-1	SHORT flame Step sequence	R -> L	2.66s	82-84
33	Step 5>8>11	SHORT flame Step sequence	L -> R	0.92s	85-86
34	Step 11>8>5	SHORT flame Step sequence	R -> L	0.92s	87-89
35	Step 6>10	SHORT flame Step sequence	L -> R	0.75s	90-91
36	Step 10>6	SHORT flame Step sequence	R -> L	0.75s	92-94
37	Step 4>6>8>10>12	SHORT flame Step sequence	L -> R	1.27s	95-96
38	Step 12>10>8>6>4	SHORT flame Step sequence	R -> L	1.27s	97-99
39	Step 8>6>10>4>12	SHORT flame Step sequence	M>L>R>L>R	1.60s	100-101
40	Step 8>10>6>12>4	SHORT flame Step sequence	M>R>L>R>L	1.60s	102-104
41	Step from 1-15	LONG flame Step sequence	L -> R	7.78s	105-107
42	Step from 15-1	LONG flame Step sequence	R -> L	7.78s	108-109
43	Step 5>8>11	LONG flame Step sequence	L -> R	1.82s	110-112
44	Step 11>8>5	LONG flame Step sequence	R -> L	1.82s	113-114
45	Step 6>10	LONG flame Step sequence	L -> R	1.25s	115-117
46	Step 10>6	LONG flame Step sequence	R -> L	1.25s	118-119
47	Step 4>6>8>10>12	LONG flame Step sequence	L -> R	2.68s	120-122
48	Step 12>10>8>6>4	LONG flame Step sequence	R -> L	2.68s	123-124
49	Step 8>6>10>4>12	LONG flame Step sequence	M>L>R>L>R	2.88s	125-127
50	Step 8>10>6>12>4	LONG flame Step sequence	M>R>L>R>L	2.88s	128-130

### Wave Sequence List

No.	Ignition angle NO.	Description	Nozzle movement	Sequence Duration	CH5 DMX Value
51	Wave 5 -->11	Middle wave sequence	L -> R	1.87s	131-132
52	Wave 11-->5	Middle wave sequence	R -> L	1.87s	133-135
53	Big wave 1--15	LONG wave sequence	L -> R	4.08s	136-137
54	Big wave 15--1	LONG wave sequence	R -> L	4.08s	138-140
55	Wave 8-->1	Middle wave sequence	M -> L	2.09s	141-142
56	Wave 8-->15	Middle wave sequence	M -> R	2.09s	143-145
57	Wave 1-->8	Middle wave sequence	L -> M	2.31s	146-147
58	Wave 15-->8	Middle wave sequence	R -> M	2.31s	148-150
59	Wave 8-->11	SHORT wave sequence	M -> R	0.99s	151-152
60	Wave 8-->5	SHORT wave sequence	M -> L	0.99s	153-155

61	Wave 5-->8	SHORT wave sequence	L -> M	1.08s	156-158
62	Wave 11-->8	SHORT wave sequence	R -> M	1.08s	159-160

### Additional Sequences List

No.	Ignition angle NO.	Description	Nozzle movement	Sequence Duration	CH5 DMX Value
63	Step 3>13	SHORT flame Step sequence	L -> R	0.93s	161-163
64	Step 13>3	SHORT flame Step sequence	R -> L	0.93s	164-165
65	Step 3>13	LONG flame Step sequence	L -> R	1.63s	166-168
66	Step 13>3	LONG flame Step sequence	R -> L	1.63s	169-170
67	Step 8-13	SHORT flame Step sequence	M -> R	1.55s	171-173
68	Step 13-8	SHORT flame Step sequence	R -> M	1.55s	174-175
69	Step 8-13	LONG flame Step sequence	M -> R	3.24s	176-178
70	Step 13-8	LONG flame Step sequence	R -> M	3.24s	179-181
71	Step 8-3	SHORT flame Step sequence	M -> L	1.54s	182-183
72	Step 3-8	SHORT flame Step sequence	L -> M	1.54s	184-186
73	Step 8-3	LONG flame Step sequence	M -> L	3.24s	187-188
74	Step 3-8	LONG flame Step sequence	L -> M	3.24s	189-191
75	Step 3-13	SHORT flame Step sequence	L -> R	1.98s	192-193
76	Step 13-3	SHORT flame Step sequence	R -> L	1.98s	194-196
77	Step 2-14	SHORT flame Step sequence	L -> R	2.32s	197-198
78	Step 14-2	SHORT flame Step sequence	R -> L	2.32s	199-201
79	Step 8>5>11	SHORT flame Step sequence	M>L>R	0.93s	202-203
80	Step 8>11>5	SHORT flame Step sequence	M>R>L	0.93s	204-206
81	Step 5-11	SHORT flame Step sequence	L -> R	1.28s	207-209
82	Step 11-5	SHORT flame Step sequence	R -> L	1.28s	210-211
83	Wave 8-->13	Middle wave sequence	M -> R	1.70s	212-214
84	Wave 13-->8	Middle wave sequence	R -> M	1.70s	215-216
85	Wave 8-->3	Middle wave sequence	M -> L	1.60s	217-219
86	Wave 3-->8	Middle wave sequence	L -> M	1.60s	220-221
87	Wave 3-->13	LONG wave sequence	L -> R	3.06s	222-224
88	Wave 13-->3	LONG wave sequence	R -> L	3.06s	225-226
>89	8(0°)	Single Ignition LONG flame	Static	max. 8s	227-255

### ▲ DMX CONTROL

CIRCLE FLAMER X-F3600 occupies 6 channels.

Channel	Function	Value
CH1	Manual Angle setup	<b>0~255:</b> angle change from -105° to 105° <b>128:</b> straight upward (0°)
CH2	Manual Nozzle Waving Speed setup	<b>0 and 255:</b> Max Speed <b>1~254:</b> Speed increase
CH3	Ignition ON/OFF	<b>0~253:</b> Ignition OFF <b>254~255:</b> Ignition ON
CH4	Firing Duration setup	<b>0 and 255:</b> permanent fire (10s is limit duration time) <b>1~254:</b> 10~2540ms duration time (Manual firing duration = DMX Value * 10ms)
CH5	Preset sequence setup	<b>0-2:</b> no preset sequence <b>3-255:</b> preset sequence DMX value = 2 + Sequence No.*2.55 (ROUND OFF)

CH6	Mode setup	0~49: Depressurize (Emergency Stop) 50~200: Pressurize 201~255: Depressurize (Emergency Stop)
-----	------------	---

**Channel 1 (CH1) - Full Cycle Mode: Manual Angle Setup**

Angle No.	Angles	DMX Value
A1	0°	0
B1	15°	4
C1	30°	7
D1	45°	11
E1	60°	14
F1	75°	18
G1	90°	21
H1	105°	25
I1	120°	28
J1	135°	32
K1	150°	35
L1	165°	39
M1	180°	42
N1	195°	46
O1	210°	50
P1	225°	53
Q1	240°	57
R1	255°	60
S1	270°	64
T1	285°	67
U1	300°	71
V1	315°	74
W1	330°	78
X1	345°	81
A2	360°	85
B2	375°	89
C2	390°	92
D2	405°	96
E2	420°	99
...	...	...
A3	720°	170
...	...	...
E(END)	1080°	255

1. The first channel controls the firing angle. It defines to which angle the nozzle of CIRCLE FLAMER move to. The angle can be chosen anywhere between 0° to 1080° (DMX value 0 to 255).

2. The following formula can be used to calculate all other angles ∠ in degree.

$$\text{DMX Value} = \angle * 0.2361$$

**Channel 1 (CH1) - Half Cycle Mode: Manual Angle Setup**

Angle No.	Angle	DMX Value
1	-105°	0
2	-90°	18
3	-75°	36



4	-60°	54
5	-45°	73
6	-30°	91
7	-15°	109
8	0°	128
9	15°	146
10	30°	165
11	45°	183
12	60°	201
13	75°	219
14	90°	237
15	105°	255

1. The first channel controls the firing angle. It defines to which angle the nozzle of CIRCLE FLAMER move to. The angle can be chosen anywhere between -105° to +105° (DMX value 0 to 255)

2. The DMX value for angle of 0° is 127.5 (round up 128). Use this value, following formula can be used to calculate all other angles  $\angle$  in degree. Please always note the prefix of the angle

$$\text{DMX Value} = 127.5 + (\angle * 1.2145)$$

### Channel 2 (CH2): Manual Nozzle Waving Speed Setup

CH2: Nozzle Waving Speed Setup			
DMX Value	0	1-254	255
Speed	Max Speed	Incremental of Speed	Max Speed

The second channel defines the nozzle waving speed. It work together with Channel 1 for manual firing

### Channel 3 (CH3): Ignition ON/OFF

CH3: Ignition		
DMX Value	0-253	254-255
Ignition	Igniter disable (ignition OFF)	Igniter enable (ignition ON)

The third channel activates the actual ignition. If the DMX value of this channel higher than 253, the CIRCLE FLAMER will ignite.

### Channel 4 (CH4): Firing Duration setup

CH4: Manual Firing Duration setup								
DMX Value	0	1	2	3	4	.....	254	255
Firing Duration	Permanent	10ms	20ms	30ms	40ms	.....	2540ms	Permanent

The fourth channel is the firing duration setup

Below formula can be used to calculate the firing duration (ms):

$$T = \text{DMX Value} * 10$$

### Channel 5 (CH5): Program Sequence setup

The fifth Channel allows to firing a preset sequence. Three DMX values can be used for one of the programmed firing sequence from above sequence list (refer to above sequence list table).

Below formula can be used to calculate firing sequence:

$$\text{DMX Value} = 2 + \text{Sequence No.} * 2.55$$

CH5: Sequence List							
DMX Value	0~2	3~5	6~7	.....	225-226	.....	240~242
Sequence No.	N/A	1	2	.....	88	.....	94
Mode	Half Cycle Mode(180)						--
	Full Cycle Mode(360)						

## Channel 6 (CH6): Mode setup

The sixth channel can set the working mode of pump.

When the safety lock located at TEST MODE, set DMX value between 50-200 to test the system. For safety, the pumps are disabled.

When the safety lock located at USER MODE, the pump can be activated by set DMX value between 50-200. The device can generate flames under Pressurize mode.

CH6: Mode setup			
DMX Value	0-49	50-200	201-255
Mode	Depressurize Mode	Pressurize Mode	Depressurize Mode

## ▲ Control with SHOWVEN Host Controller ZK6200/ZK6300

If use SHOWVEN Host Controller ZK6200 or ZK6300 to program the CIRCLE FLAMER X-F3600, please set on Host Controller. The setting step is:

Press "F3" on Host Controller – find "Device" – choose the right device "CIRCLE FLAMER".

Host Controller with bi-directional communication with device, please allocate a unique DMX address for each unit of CIRCLE FLAMER X-F3600.

Press "Pre-heat" to start to pressurize CIRCLE FLAMER X-F3600.

Firing the preset flame effect by enter the preset sequence No. to FIRING HEIGHT. FIRING DURATION is meaningless.

**F3 CONFIG**

Start No. : 1  
 End No. : 10  
 Device : CIRCLE FLAMER  
 Mode Selection : User Mode  
 Repeat Time Mode : Repeat Period Mode  
 DMX IN : ON  
 DMX Address : 1  
 CAN : OFF  
 Trigger Source : HAND  
 Audio Level : 2  
 Audio Filter Delay : 100ms

**F1 MAIN**

Synchronizariion CIRCLE FLAMER No. 1-10 ☰

FILE NO.	FIRING HEIGHT	FIRING DURTN	TRIG DELAY	REPEAT DELAY	REPEAT COUNTS
1	31	0.5s	0.0s	10.0s	1

Terminal Monitor

1	2	3	4	5	6
7	8	9	10	11	12
13	14	15	16	17	18

From 1-15 Steppsequence short 2.4s

MAIN    FILE SELECT    CONFIG    ABOUT

## ▲ Operation

### 1. Safety Distance

#### Definition and Instructions

Safety distance for CIRCLE FLAMER X-F3600 divided into two parts safety radius around machine (a) and safety distance at firing direction (b). No person and flammable materials are allowed to stay inside the safety isolation zone when flamer was armed.

The safety radius around machine depends on the firing height (nozzle size).

For safety distance at firing direction equals to maximum firing height \* 1.5.

Nozzle Type	Max. Flame Height	Safety Radius around (a)	Safety Distance at Firing Direction (b)
SFSMA027 Nozzle EL	6m	2m	9m
SFSMA024 Nozzle L	8m	2.5m	12m
SFSMA025 Nozzle M	10m	3m	15m

When under full cycle mode, CIRCLE FLAMER X-F3600 safety isolation zone is a three-dimensional space with a circular cross-section with radius of b, and thickness of 2a, as show in below picture. Unauthorized persons and objects are strictly prohibited from entering. Depending on the firing sequence / angles the safety isolation area changes accordingly.

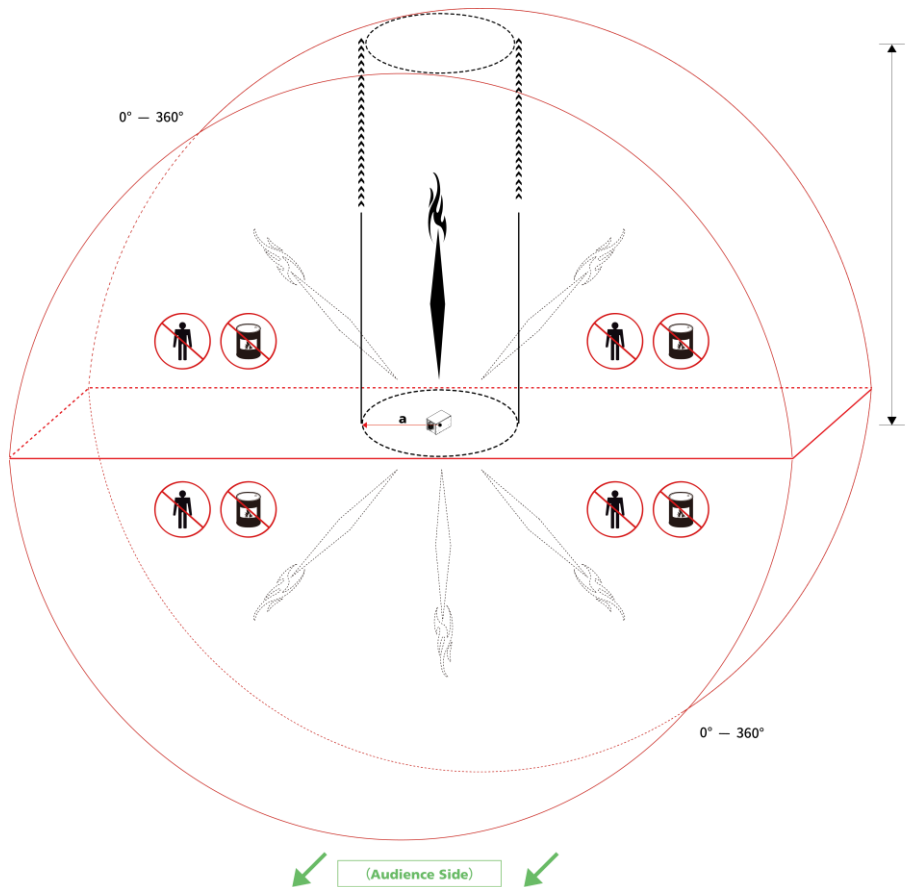

When use half cycle mode, please refer to the safety distance on CIRCLE FLAMER X-F1800 manual.

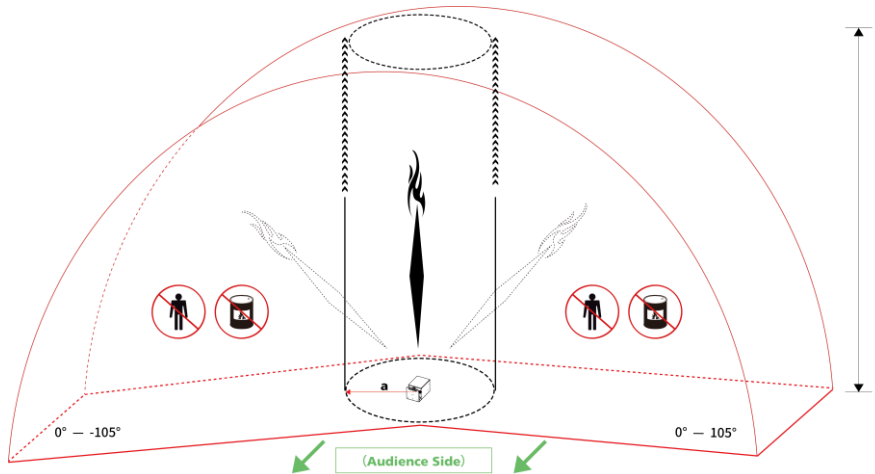

### Safety distance in windy environment

The safety isolation zone radius (a) increase with wind direction and wind speed (v, m/s). The safety distance in windy conditions can be calculated as below:

For Nozzle L:  $a = 2.5 + v$ ;

For example when the wind speed is 3m/s, we use the Nozzle L, then the safety isolation zone radius should be 5.5m.

**CAUTION:**

When the wind speed  $\geq 8\text{m/s}$  (wind force  $\geq 5$ ), please use it with caution. When wind speed  $\geq 17\text{m/s}$  (wind force  $\geq 8$ ) , please stop use flamer.

**Direction Explanation**

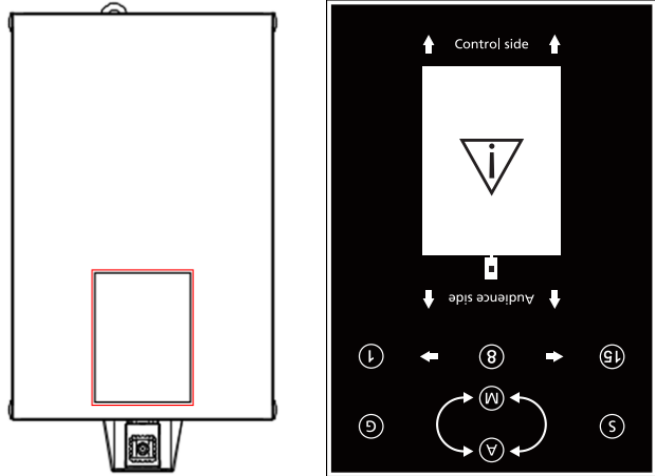

There is direction explanation on top panel of CIRCLE FLAMER X-F3600 as show above picture.

1. 1 to 15 is the firing angle of CIRCLE FLAMER X-F3600, Far Right is position 15, Middle is position 8, Far Left is position 1.
2. AMGS is the firing direction when running in full cycle mode, A is downward, M is upward, G is left side, S is right side. For more detail please refer to angle definition under full cycle mode.
3. Audience side and control side are indicated in above picture

Note: in order to indicate correct direction, please place the top panel correctly.

**Label of CIRCLE FLAMER X-F3600**

The label is at rear panel of machine and information is show as below.

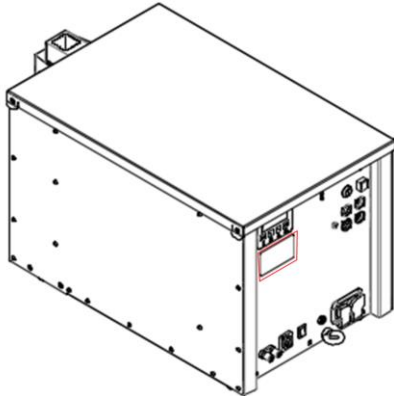

<b>CIRCLE FLAMER</b>		<b>SHOWVEN®</b>
AC 100V-120V 50/60Hz	380W	
AC 200V-240V 50/60Hz		
Showven Technologies Co.,Ltd. www.showven.cn info@showven.cn +86-731-83833068 No.1 Tengda Road, Liuyang Economic & Technical Development Zone, 410300, Changsha, Hunan, P.R.China		CE, RoHS, WEEE symbols MADE IN CHINA
	Hazardous voltage inside, please do not remove the cover unless by trained personnel.	Serial Number  9 788087 049099
	People and flammable materials should keep a certain safety distance around the machine and in the firing directions. Check user manual for detail safety distance information.	

**Fuels for CIRCLE FLAMER X-F3600**

1. Water content in fuel should less than 0.5%
2. For maximum safety, please use fuel with flash point between 60-80°C, ISOPAR L is highly recommended.
3. Ethanol is not suggested due to three reasons, first ethanol is highly flammable makes it not as safe as ISOPAR; secondly the color of flame is very weak; thirdly there are always high water content (> 0.5%) in ethanol.
4. Colored fuels are forbidden to use on CIRCLE FLAMER X-F3600 it may damage the machine. SHOWVEN excludes liability for the losses, damages and accidents caused by not using qualified fuels in accordance with this requirement.

Always have a dry powder fire extinguisher, a CO<sub>2</sub> fire extinguisher and an extinguishing blanket next to the equipment in case of needed. And someone must be on duty during operation. In case accident occurs, a dry powder fire extinguisher can be used when the fire is large, and a carbon dioxide fire extinguisher can be used when the fire is small.

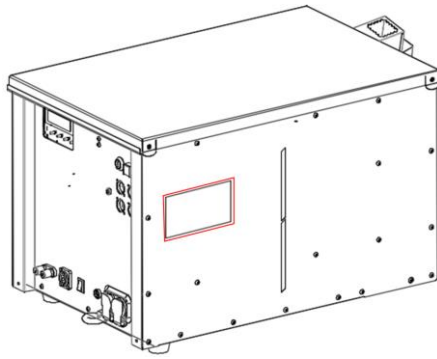

## 2. Install CIRCLE FLAMER X-F3600

- Choose the correct nozzle, ensure the installation position of CIRCLE FLAMER X-F3600 meet above safe distance requirements. New CIRCLE FLAMER X-F3600 supplied with a nozzle M which generate up to 10m flame.
- Horizontal installation is highly recommended for CIRCLE FLAMER X-F3600.
- Make sure CIRCLE FLAMER X-F3600 is securely installed. For truss installations always connect with safety rope to ensure extra safety. If there is any other national or regional guidelines please follow it accordingly.

## 3. Connect Power and DMX cable to CIRCLE FLAMER X-F3600

Before power and/or DMX cable connection, make sure safety lock of CIRCLE FLAMER X-F3600 stay at TEST MODE as below.

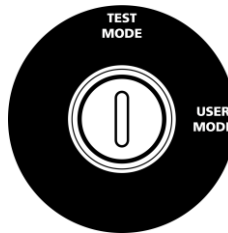

### If control by DMX, follow below steps:

- Connect a power cable to the POWER IN socket of CIRCLE FLAMER X-F3600. Connect the other end of power cable to the power source. Make sure power supply in consistent with the rated voltage of the equipment, and the socket must well grounded.
- Each unit of CIRCLE FLAMER X-F3600 can be connected to power supply directly. If connect machine in sequence, please connect a power link cable to the POWER OUT of previous machine, connect the other end of the power link cable to POWER IN of the next machine. Do not connect exceed units to a single electrical circuit.
- Power on CIRCLE FLAMER X-F3600
- Assign a DMX address for each unit of machine. If use SHOWVEN host controller or FXcommander to control the machine please allocate a unique DMX address for each unit of machine.
- Connect a DMX cable to the DMX IN socket of first unit of X-F3600, another head of this DMX cable connect to DMX console (such as FXcommander). **Make sure the DMX console is powered off.**
- Connect a DMX cable to the DMX OUT socket of previous X-F3600, and the other end to the DMX IN of next machine. Connect all devices in series in this way.
- Suggest to plug in a DMX terminator into the DMX OUT in last unit of machine to improve signal reliability. Signal amplifier is required for long distance (>200m) DMX signal transmission.

### If control by 9-60V pyro signal, follow below steps:

- Connect a power cable to the POWER IN socket of CIRCLE FLAMER X-F3600. Connect the other end of power cable to the power source. Make sure power supply in consistent with the rated voltage of the equipment, and the socket must well grounded.
- Each unit of CIRCLE FLAMER X-F3600 can be connected to power supply directly. If connect machine in sequence, please connect a power link cable to the POWER OUT of previous machine, connect the other end of the power link cable to POWER IN of the next machine. Do not connect exceed units to a single electrical circuit.
- Connect the power control cables to the 9-60V pyro signal connector on CIRCLE FLAMER X-F3600.

- d) Connect the other end of power control cables to the pyro controller (9-60V external trigger source).  
Make sure the pyro controller is powered off
- e) Power on all CIRCLE FLAMER X-F3600
- f) Set the Ext Ignite to ON status in advanced interface, set the firing sequence by choose a sequence No. at Set Ext Sequence.

#### 4. Power ON the DMX console or pyro controller

#### 5. Programming

Program the CIRCLE FLAMER X-F3600 with DMX console.

#### 6. Test the ignition function of CIRCLE FLAMER X-F3600

Test the ignition function of CIRCLE FLAMER X-F3600, we can check whether the igniters of each unit of X-F3600 is working fine. Due to the safety switch is stay at TEST MODE the pump won't work, there will be only ignition while no fuel spray out, so no flames generated.

#### 7. Fill the CIRCLE FLAMER X-F3600

Please fill the machine with qualified fuel. The fuels suggested on CIRCLE FLAMER are ISOPAR, ISOPROPANOL, please make sure water content in fuel should less than 0.5%.

#### 8. Firing

- a) Double confirm the prescribed safety isolation zone is clear, no person, animal or other property within this region.
- b) Switch the safety switch of CIRCLE FLAMER X-F3600 to USER MODE.

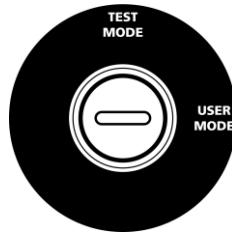

- c) Pressurize CIRCLE FLAMER X-F3600.
- d) Firing, the operator should always have a clear view of the device, so that he/she can stop the show immediately when there is danger.

#### 9. Depressurize

Depressurize all CIRCLE FLAMER after use or if not use for a long time during the show we also suggest to depressurize to ensure the safety.

#### 10. Power OFF

- a) Power OFF DMX console
- b) Switch safety switch of CIRCLE FLAMER X-F3600 to TEST MODE
- c) Power OFF CIRCLE FLAMER X-F3600
- d) Unplug power cable, DMX cable.

### ▲ Nozzles and Nozzle Replacement

#### Nozzles and Flame Height

**Nozzle M:** (standard configuration)

Short flame: 5-7m,

Long flame: 8-10m.

**Nozzle L:**

Short flame: 3-5m,

Long flame: 6-8m.

**Nozzle EL:**

Short flame: 3-4m,

Long flame: 4-6m.

## Nozzle Replacement Wrench



Use 14mm outer hexagon socket wrench to disassemble the nozzle, clean the nozzle and nozzle socket with air gun (air compressor), change a different nozzle and install it.

## Nozzle Installation (available in new design)

Please assemble the stainless steel gasket(RMSMA530), O ring and nozzle main part according to below picture. The O ring should be inside the stainless steel gasket, otherwise it may leads to fuel leakage.

Use nozzle replacement tool outer hexagon socket wrench to tighten the nozzle.

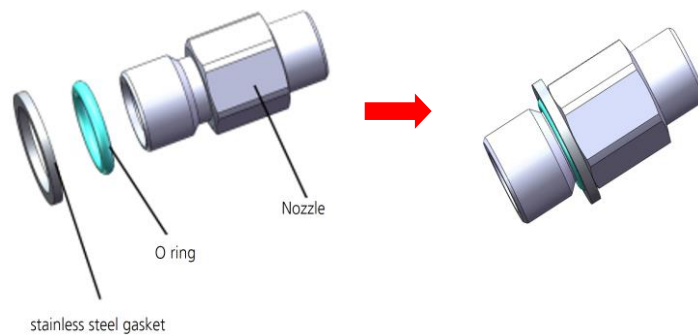

## ▲ Igniter Position Adjustment

Whenever changed the nozzle or ignition is not good, please check igniter pole position according to below parameters. Check the ignition success rate after adjustment by firing.

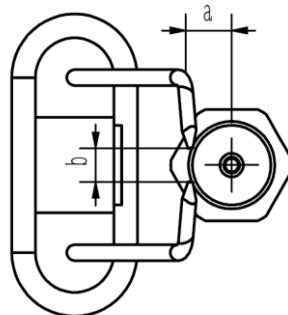

Nozzle	a (mm)	b (mm)
M	8±0.5	4±0.5
L		
EL		

**Note:** Do unplug the power cable when service flamer.

## ▲ Waterproof cover installation

Hang the waterproof cover on the rear panel side of the top cover and fix it with 2pcs of M5\*10 screws as shown in below picture.

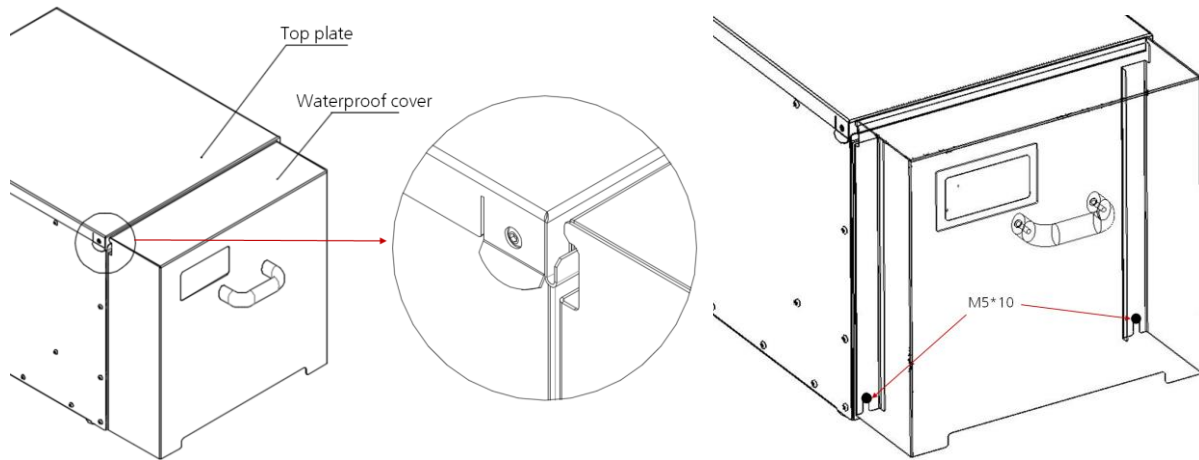

## ▲ Battery Recommendation

CIRCLE FLAMER can be driven by battery, for use of Battery power supply: CIRCLE FLAMER X-F1800 with stable internal circuit design, please support X-F1800 with battery voltage higher than 12V. The driving speed of motor won't change because of the decrease of battery power supply.

Battery options: 12V lead-acid battery (above 30AH, with more than 24h standby).

For Lithium battery, please use battery with output above 30A. Socket type: NEUTRIK-NL4FX, 4 pin audio connector (1+ connect 12V anode, 1- connect 12V cathode). Connecting power cables should above 14AWG.

## ▲ Maintenance

1. To maintain the system in good performance and running status, it is recommended to running the device at least once per month.
2. Check the ignition probes both before and after each show, if there is any foreign objects on it please clean it up.
3. Maintenance of the nozzle: Nozzle needs to be cleaned from time to time, and it is recommended that once every six months (depending on the environment and frequency of use). In the process of using the equipment, if the flame shape is seriously deformed or the fuel injection line is significantly deformed or coarsened, the nozzle should be removed immediately for cleaning. If after clean, there are still problems please replace new nozzle.
4. Maintenance of the O-ring: If it is found that the O-ring of the nozzle is damaged or ageing when cleaning the nozzle, the O-ring should be replaced in time (material and size of O-ring: fluororubber O-ring, the outermost diameter is 14 mm, and the line diameter is 2 mm).

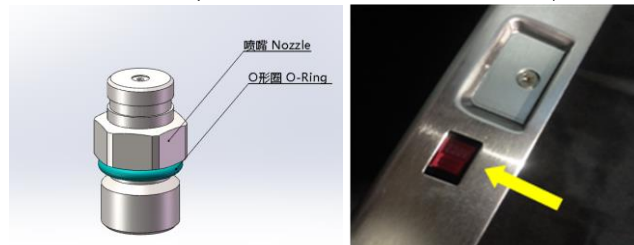

5. Switchable power input design, switchable between 110V and 220V as show above picture (voltage will show on it). The power supply is located on the side of the electric control, and you should remove the cover before switch it.



### △ **Optional Parts for CIRCLE FLAMER X-F3600**

Part. No.	Description	pcs / unit
RMWAS025	Fluorine O ring, outer $\phi$ 14, wire diameter is 2 mm	1
RMBOT036	Safety ring	1
RMEMD062	Wireless receiver ( for wireless control with FXcommander)	1
SFSMA025	nozzle M	1
SFSMA024	nozzle L	1
SFSMA027	nozzle EL	1
SFMET944	Nozzle disassemble tool	1
RMSMA291	Angle block bar	2
SFMET455	Waterproof cover for control panel	1

### △ **Warranty Instructions**

- √ Sincere thanks for your choosing our products, you will receive quality service from us
- √ The product warranty period is one year. If there are any quality problems within 7 days after shipping out from our factory, we can exchange a brand new same model machine for you
- √ We will offer free of charge maintenance service for machines which with hardware malfunction (except for the instrument damage caused by human factors) in warranty period. Please don't repair machine without factory permission

#### **Below situations NOT included in warranty service:**

- √ Damage caused by use unqualified fuels;
- √ Damage caused by improper transportation, usage, management, and maintenance, or damage caused by human factors;
- √ Disassemble, modify or repair products without permission;
- √ Damage caused by external reasons (lightning strike, power supply etc.)
- √ Damage caused by improper installation or use;

For product damage not included in warranty range, we can provide paid service.  
Invoice is necessary when applying for maintenance service from SHOWVEN.





# SHOWVEN<sup>®</sup>



**Showven Technologies Co., Ltd.**

Tel: +86-731-83833068

Web: [www.showven.cn](http://www.showven.cn) E-mail: [info@showven.cn](mailto:info@showven.cn)

Add: No.1 Tengda Road, Liuyang Economic & Technical Development Zone, Changsha, Hunan, 410300,  
P.R.China