

USER MANUAL

Fake Flame X-SH1

V1.0

2024/10/01



SHOWVEN Technologies Co., Ltd.

Thanks for choosing SHOWVEN® Fake Flame, we wish it will bring you lots of exciting moments. Please read the following manual carefully before operating this product.

Δ **SAFETY CONSIDERATIONS**

- ∨ Unauthorized repair are prohibited, it may cause serious incident.
- ∨ Make sure power supply in consistent with the rated voltage of the equipment, and the socket must well grounded. Unplug and turn off the machine when not use.
- ∨ FAKE FLAME can be used both indoor and outdoor, please keep the machine dry and clean when storage.
- ∨ Not use the machine in high temperature.
- ∨ Installed in well ventilated area, ensure at least 50cm space around the machine.
- ∨ For adult use only, keep it away from children, fire, inflammable and explosive articles.
- ∨ If the machine fails to work, please stop operation and unplug the machine. Check water tank, fuse, power connection etc. carefully, if can't solve the problem, please contact SHOWVEN® or your local SHOWVEN® partner for advise.
- ∨ The device shall not be altered and applied to other use purpose.

Δ **Description**

SHOWVEN® Fake Flame simulate the gas flames, but uses no flammable materials. It create a very realistic artificial flame by projecting colored light to water mist. It is designed for theme park, theater, TV show etc occasions where a flame effect is desired while real flame is not allowed.

Δ **Technical Specifications**

- ∨ **MODEL:** Fake Flame X-SH1
- ∨ **DIMENSION:** 760×460×660mm
- ∨ **WEIGHT:** 35kg
- ∨ **VOLTAGE:** AC 220-240V / AC 100-120V,50/60Hz
- ∨ **FUSE:** 15A/240V
- ∨ **POWER:** 800W
- ∨ **LED POWER:** 3W×68pcs
- ∨ **TANK CAPACITY:** 12L
- ∨ **CONSUMABLE:** Water (purified water is preferred)
- ∨ **INTERFACE:** 3-PIN and 5-PIN XLR
- ∨ **CONTROL:** DMX (4 channels), Wireless remote
- ∨ **FAKE FLAME HEIGHT:** Around 1-2m
- ∨ **FAKE FLAME HEIGHT ADJUSTABLE:** YES
- ∨ **FAKE FLAME BRIGHTNESS ADJUSTABLE:** YES

△ Product Overview

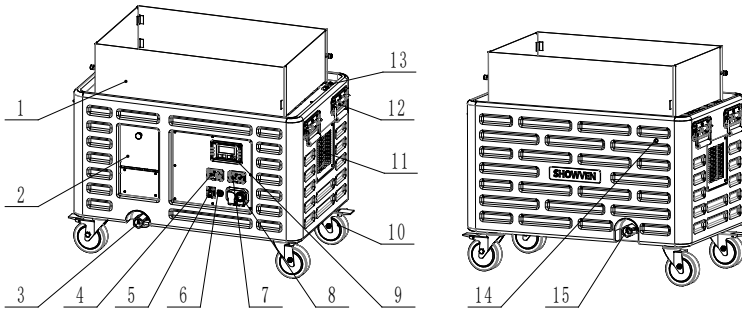

1. Baffle plate
2. Atomizing water tank filling port
3. Atomizing water tank drain
4. 3-PIN DMX
5. Power switch
6. Fuse
7. 5-PIN DMX
8. Power Input
9. LCD display
10. Casters
11. Air inlet
12. Handle
13. Reservoir water tank filling port
14. Reservoir water tank overflow
15. Reservoir water tank drain

Δ Operation Panel

1. Control button area

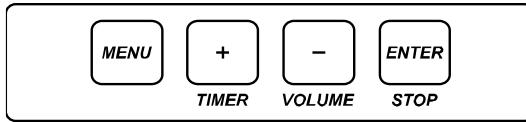

MENU: switch through setup menu;

+: Parameter up; multiplex "TIMER" (fake flame output time)

-: Parameters down; multiplex "VOLUME" (fake flame output start)

ENTER: confirm and save parameters (screen will blink once when save successfully); multiplex "STOP".

NOTE: Screen will switch to main interface automatically if not press any button in 15s.

Δ Interface

1. Welcome interface

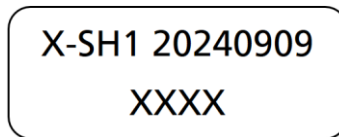

First Line: Product model and software version

Second Line: serial No. of this unit of machine

2. Main interface

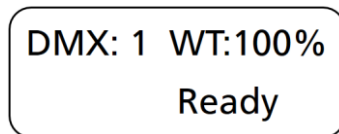

First Line: DMX address and reservoir tank water level.

Second Line: Shows machine working status (alert or error information will also show it here)

3. Error information

Error information	Explanation
E3 Water Sensor I	Low water level of atomizing water tank, system is pumping water to atomizing water tank or liquid level sensor malfunction
E4 Water Sensor O	Low water level of reservoir water tank, need to feeding the water tank or liquid level sensor malfunction

4. Setting Menu

Press "MENU" switch through setup menu.

Options	Range	Default	Explanation
DMX Address	1~512	1	DMX address setup
Flame Size	1%-100%	100%	Fake flame volume setup
Flame Height	1%-100%	100%	Fake flame height setup
Flame Bright	1%-100%	100%	Fake flame brightness setup
Ultrasonic Num	High / Low	High	Working ultrasonic atomizer block QTY
Interval Set	1-600s	30s	Set flame output interval
Duration Set	1-600s	30s	Set flame output duration
Wireless Set	ON / OFF	ON	Wireless function set
语言(Language)	中文/English	ENGLISH	Language switch
Power Off save	ON / OFF	ON	Save the current working status of the device after power failure and restart

5. Advanced Menu

Press "MENU" and hold for 3s enter advanced menu, press "MENU" to switch through setup menu.

Options	Range	Default	Explanation
Drive Test	OFF / Pump / Fan / Ultrasound / Valve / LED plate	OFF	Activate related part for 1s when running drive test
Sensor Disp			Displays ultrasonic sampling values and their corresponding quantities

Δ DMX Channel

SHOWVEN® occupies 4 functional channels.

Channel	Function	DMX Value
CH1	Flame size	0-5: OFF 6-255: Flame size increase as dmx value increase
CH2	Ultrasonic Number	0-5: OFF 6-128: low water mist density generation 129-255: high water mist density generation
CH3	Flame Height	0-5: OFF 6-255: Flame height increase as dmx value increase
CH4	Flame Brightness	0-5: OFF 6-255: Flame Brightness increase as dmx value increase

Δ Wireless Control

Our Fake Flame can be controlled wirelessly with our FXmote. Before use the wireless function please make sure machine was ready, wireless status was ON, and no DMX cable connection

Operation step:

1. Turn on FXmote, press "MENU" on FXmote, set "DEVICE" to "FOG";
2. Power on Fake Flame, press "MENU" on Fake Flame, set "Wireless Set" to "ON", press "ENTER" to save the change;
3. Press "SET" on FXmote to match the Fake Flame unit and FXmote. Fake Flame LCD display will flash once for a successful pairing;
4. Press only of the "ON" button on FXmote to firing Fake Flame;
5. Press only of the "OFF" button on FXmote to stop firing.



Δ Operation

1. Installation

- ① Check the machine and accessories, ensure it is in good status. Place the machine on a flat surface, tilting may result in inaccurate water level alarm.
- ② Open the baffle plate and screw it tight

2. Power ON Fake Flame

Connect the machine to suitable rated power supply and power on machine. Please ensure power supply meets the requirement. Always connect the machine to a protected circuit and ensure it is properly grounded.

3. Fill the water tank

Fill the reservoir water tank with pure water until the alarm of water shortage on LCD screen (E3, E4) disappear. Operator can also connect the machine to water supply with G1/6 pipe connector, machine will refill it automatically.

4. Setting

Set the fake flame height, brightness, ultrasonic atomizer block etc. according to the application scenario.

If use a DMX to firing, please also set the DMX address and connect with a DMX cable.

Multi units of fake flame can be connected in daisy chain via XLR IN/OUT and controlled by DMX console such as FXcommander to form a fake flame wall.

5. Firing

By manual, please press "-"(VOLUME) to start generate of fake flame, press "ENTER"to stop.

By DMX console control, please follow the previously introduced DMX channel information to firing the machine.

By FXmote wireless remote control, please follow above wireless control information.

6. Power OFF and clean up

- ① To turn off the machine, please POWER OFF and unplug the power cable.
- ② Close the baffle plate.
- ③ For transportation or not use for a long time, please drain the water inside both reservoir tank and atomizing water tank.

Δ **Maintenance**

1. Running the machine at least once per month.
2. Clean machine regularly avoid dust, liquid accumulate on the machine.
3. Whenever storage or not use the machine for a period of time, please drain the machine and keep it dry.
4. Please check water tank from time to time, if there is scale formed, please cleaned up in time. Avoid using water that is prone to scale formation.

Δ **Warranty Instructions**

- ✓ Sincere thanks for your choosing our products, you will receive quality service from us.
- ✓ The product warranty period is one year. If there are any quality problems within 7 days after shipping out from our factory, we can exchange a brand new same model machine for you.
- ✓ We will offer free of charge maintenance service for machines which with hardware malfunction (except for the instrument damage caused by human factors) in warranty period. Please don't repair machine without factory permission.

Below situations NOT included in warranty service:

- ✓ Damage caused by use unqualified water or other liquid.
- ✓ Damage caused by improper transportation, usage, management, and maintenance, or damage caused by human factors;
- ✓ Disassemble, modify or repair products without permission;
- ✓ Damage caused by external reasons (lightning strike, power supply etc.)
- ✓ Damage caused by improper installation or use;

For product damage not included in warranty range, we can provide paid service. Invoice is necessary when applying for maintenance service from SHOWVEN®.

SHOWVEN[®]



Showven Technologies Co., Ltd.

Tel: +86-731-83833068

Web: www.showven.cn E-mail: info@showven.cn

Add: No.1 Tengda Road, Liuyang Economic & Technical Development Zone, Changsha, Hunan,
410300, P.R.China