

# USER MANUAL

## Maiman 30W/40W/60W

V1.1

2024/11/01



Showven Technologies Co., Ltd.



Thanks for choosing SHOWVEN® Maiman series laser, we wish it will bring you lots of exciting moments. Please read the following manual carefully before operating this product.

## Δ **Safety Considerations**

Before proceeding any further, please read the following safety considerations very carefully. It could help you avoid dangerous and hazardous situations which could lead to serious injury or property damage. This product must always be operated by skilled personnel who are familiar with laser and information in this manual. Do not operate the laser without first reading and understanding all safety and technical data in this manual.

### **CRITICAL SAFETY INFORMATION:**

1. Laser is dangerous! Laser are different from any other light source. If the laser is installed and used improperly, it may cause permanent eye damage and blindness. Always avoid exposing your eyes or skin to direct or scattered light from the laser. The energy density of laser is thousands of times higher than that of any other light source. This concentration of light can cause immediate blindness in the eye, primarily by burning the retina (the light-sensitive part of the back of the eye). Even if you can't feel the "heat" from the laser beam, it can still potentially injure or blind you or your audience. Even very small amounts of laser light can be potentially dangerous even over long distances. Laser eye damage occurs faster than the blink of an eye. It is incorrect to think that because these laser entertainment devices use high-speed scanning laser beams that single laser beam exposure to the eyes is safe, it can also cause irreversible damage to the eyes.
2. It is prohibited to use any camera or mobile phone to shoot directly at the laser. It will cause damage to your equipment.
3. "WARNING"! This laser light is a Class 4 laser device. A laser beam should never be scanned onto an audience. The output beam of the laser light must exceed the audience and be at least 3 meters above the ground.
4. Avoid exposing eyes or skin to direct or scattered laser light. Never look directly into a laser beam. Be aware that lasers can burn the eye retina, skin or cause fires if not used correctly.
5. Do not point the laser at people or animals.
6. Do not aim the laser at areas where people may be exposed, such as uncontrolled balconies etc.
7. Never look directly into laser aperture if the laser system is switched on.
8. Always check for reflective surfaces such as windows, mirrors, and shiny metal objects within the laser range – these can be very dangerous.
9. When projecting the laser outdoors, avoid pointing the laser at aircrafts, buses, trains, etc.
10. Never point an unterminated laser beam at the sky.
11. Do not use the laser if the housing is damaged or the optical system is damaged in any way.
12. Never leave the laser system unattended when it 's switched on.
13. Never hesitate to use the Emergency STOP if you think there's a fault within the laser system or a potential danger to a person/object caused by the laser performance.
14. Any laser system classified as a Class 4 laser must be used with caution. If you are an inexperienced laser operator, we strongly recommend that you attend a laser display safety course before you use this laser system in public areas.

**GENERAL SAFETY INFORMATION:**

1. Before connecting the power supply, **make sure power supply is consistent with the rated voltage of the equipment, and the socket must well grounded.**
2. Please unplug the power plug and turn off the machine when not in use.
3. Make sure the power cord is not crimped or damaged. Never disconnect the power cord by pulling or pulling on the cord.
4. After installation and before public use, test the laser to ensure it is working properly. Do NOT use if any defects are detected.
5. Always disconnect the power supply before cleaning the machine surface, replacing the fuse or service the machine. Fuse specification: 10A.
6. This product is not intended for severe weather conditions such as storm rain, typhoon, hurricane, hail, etc. To prevent the risk of fire, falling or damage of machine please do NOT use in those severe weather.
7. For truss installation, safety accessories such as safety ropes, clamps must be used to fix the machine to the truss to ensure that the installation is stable before use.
8. It is prohibited to open the housing and repair it by yourself, otherwise it may cause serious accidents. Do not attempt to service equipment except in a controlled environment with trained personnel. Repairs performed by non-professionals may result in equipment damage or malfunction, as well as exposure to hazardous laser light.
9. The construction of this equipment should not be altered, the device shall not be altered and applied to other use purpose.
10. Legal requirements for the use of laser lights vary from country to country and it is the user's responsibility to use the equipment in accordance with the legal requirements of the location/country of use.
11. Please retain this user manual for future reference. If you sell/rent this product to other users, please make sure they receive this document as well. If you lost this manual please always contact [info@showven.cn](mailto:info@showven.cn) for a new one.

**Disclaimers:**

SHOWVEN technologies Co., Ltd holds no responsibility for injuries or damages caused by the use of this laser display equipment. SHOWVEN excludes liability for unsafe situations, accidents and damages resulting from:

1. Ignoring warnings or regulations as shown on product housing or this manual.
2. Use for other applications or circumstances other than those indicated herein.
3. Changes to the device, including use of non-original spare parts, lack of maintenance etc.
4. Dismantling device without authorization from SHOWVEN.
5. Use this machine by unqualified or untrained personnel.
6. Improper use of machine.

## Δ Warning Labels

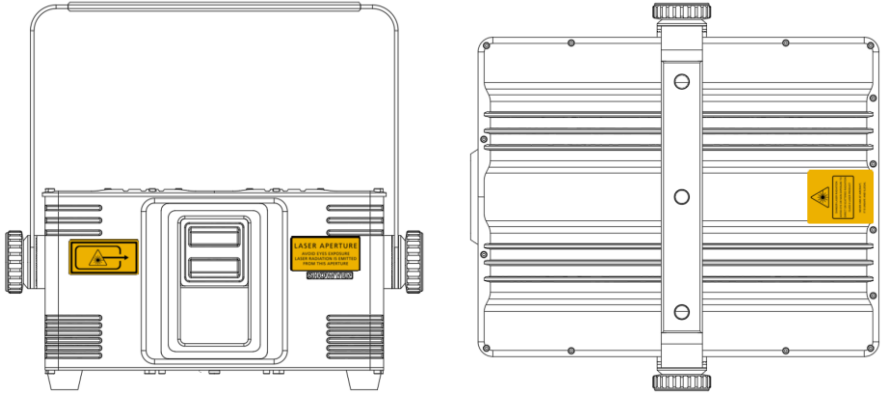

Warning Label

According to IEC 60825-1 regulations, the laser with continuous high-output greater than 500mW belongs to Class IV, Class 4 laser. The optical warning label is as follows, please pay attention!



## Δ Product Description

The laser is a device that creates continuous visible light energy waves (streams of photons that are referred to as "laser radiation") with the same amplitude and phase that are flowing in the same direction to form a laser beam. SHOWVEN Maiman series full-colour RGB lasers using premium semiconductor laser diodes as the light source, ensure bright colors, high brightness, and realistic animation effects; using high-speed deflection scanning system ensure stable output images.

Dual-layer structure design, IP65 rated enclosure. Multi safety configurations, complete connectors, Quick self-locking 360° rotatable handle, TEC cooling and PWM fan control etc. advanced features makes it versatile for festival, outdoor show, fireworks, architectural etc. applications.

### Functional Characteristics

**Source / Type:** Semiconductor laser diode, Full-colour RGB laser projector

**Control:** FB4 (optional), Ethernet, DMX, ILDA, Auto, SD card, Sound

**LCD display information:** Safety switch, E-stop alarm, Auto temp. control

**Safety standard:** IEC60825-1

**Laser level:** Class IV

**Intelligent protection:** Auto abnormal checking (in case any abnormal detected laser will shutdown automatically), Shutter actuator (optional).

**Work temp.:** -20 - 40°C

## Δ Control Panel Description

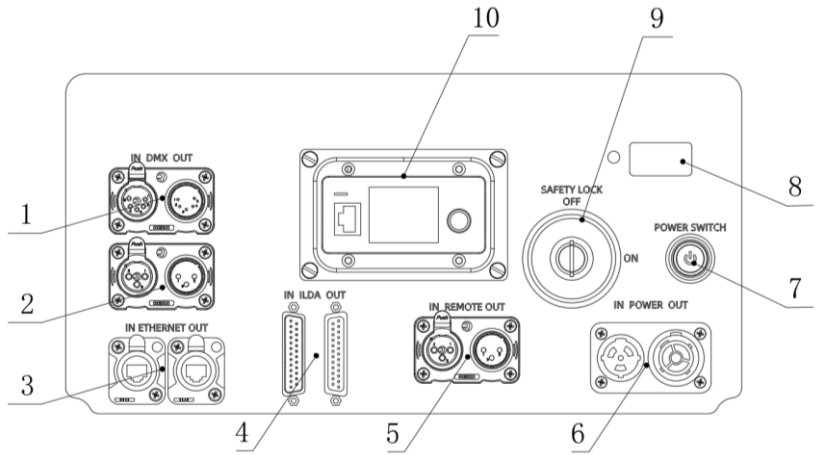

1. 5-pin DMX IN/OUT
2. 3-pin DMX IN/OUT
3. ETHERNET IN/OUT
4. ILDA DB25 IN/OUT
5. REMOTE IN/OUT (e-stop)
6. Power IN/OUT
7. Power Switch
8. LCD display (display info: safety switch status, E-stop alarm, casing temp. T0, T1)
9. Safety Lock
10. FB4 operational panel (rotate operation knob, LCD display, SD card slot)

## Δ Maiman 30

### Dimension

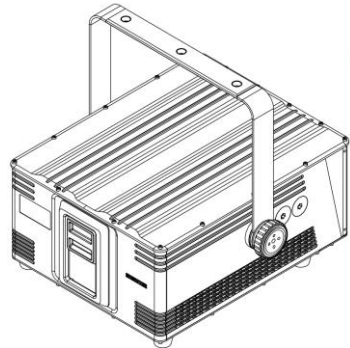
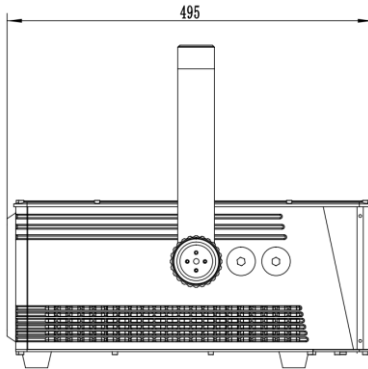
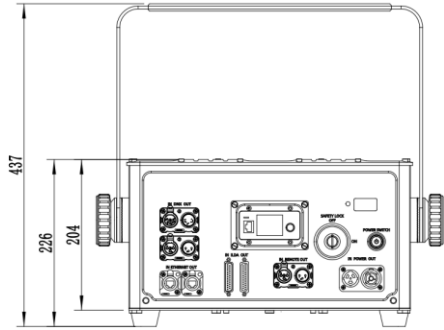
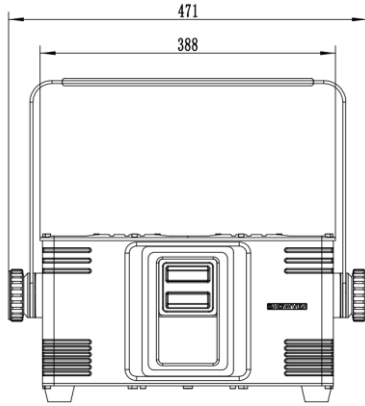

### Technical Specifications

**Model:** Maiman 30

**Output:** 30W

**Dimension:** 495×471×226mm

**Weight:** 27kg

**Power Input:** AC100-240V, 50/60Hz

**Wavelength:** 638nm (R), 520nm (G), 445nm (B)

**Scanning System:** ±30°, 35K

**Analogue modulation:** 100K, Analog/TTL

**Beam Size:** 6×7mm

**Beam Divergence:** <1.2mrad

**Cooling System:** TEC cooling

**Waterproof Level:** IP65

**Safety Features:** Safety Key, Remote E-stop (can be connected in series), scan-fail safety

**Other Features:** PWM intelligent speed control cooling fan; Quick self-locking 360° rotatable handle; Dual-layer structure design, IP65 rated enclosure; convenient beam alignment structure, easy maintenance.

## Δ Maiman 40

### Dimension

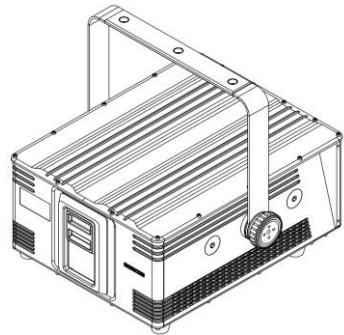
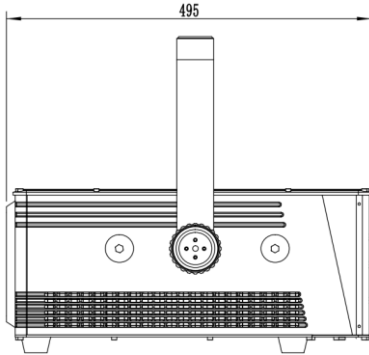
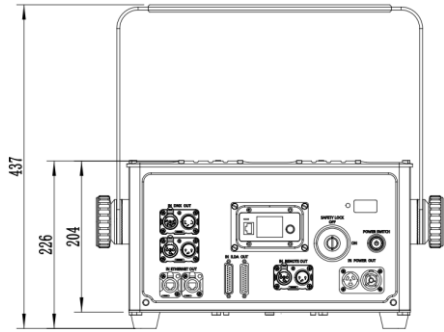
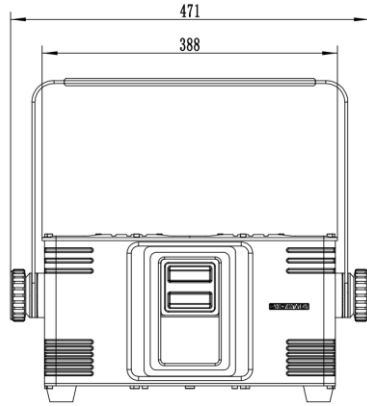

### Technical Specifications

**Model:** Maiman 40

**Output:** 40W

**Dimension:** 495×471×226mm

**Weight:** 29kg

**Power Input:** AC100-240V, 50/60Hz

**Wavelength:** 638nm (R), 520nm (G), 445nm (B)

**Scanning System:** ±25°, 30K

**Analogue modulation:** 100K, Analog/TTL

**Beam Size:** 6×8mm

**Beam Divergence:** <1.2mrad

**Cooling System:** TEC cooling

**Waterproof Level:** IP65

**Safety Features:** Safety Key, Remote E-stop (can be connected in series), scan-fail safety

**Other Features:** PWM interelligent speed control cooling fan; Quick self-locking 360° rotatable handle; Dual-layer structure design, IP65 rated enclosure; convenient beam alignment structure, easy maintenance.



## Δ Maiman 60

### Dimension

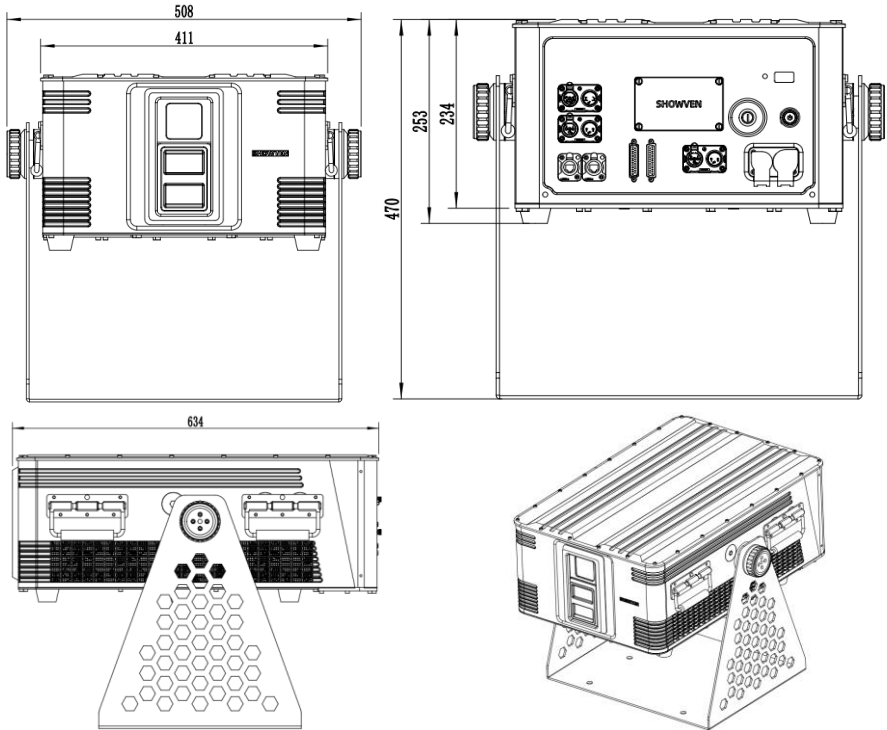

### Technical Specifications

**Model:** Maiman 60

**Output:** 60W

**Dimension:** 634×508×253mm

**Weight:** 50kg

**Power Input:** AC100-240V, 50/60Hz

**Wavelength:** 638nm (R), 520nm (G), 445nm (B)

**Scanning System:** ±20°, 25K

**Analogue modulation:** 100K, Analog/TTL

**Beam Size:** 7×12mm

**Beam Divergence:** <1.5mrad

**Cooling System:** TEC cooling

**Waterproof Level:** IP65

**Safety Features:** Safety Key, Remote E-stop (can be connected in series), scan-fail safety

**Other Features:** PWM interlligent speed control cooling fan; Quick self-locking 360° rotatable handle; Dual-layer structure design, IP65 rated enclosure; convenient beam alignment structure, easy maintenance.

## Δ Quick Operation Sheet

### 1. Installation

For safety, laser should be installed on a stable truss or elevated platform. Please also use safety rope and clamp for extra safety. International laser safety regulations require that laser products must be operated as shown below, with a minimum vertical distance of 3 meters between the floor and the lowest laser beam. In addition, a horizontal distance of 2.5 meters is required between the laser and the audience or other public spaces; in addition, the left and right sides of the laser light should be at least 15cm away from obstacles to ensure smooth heat dissipate.

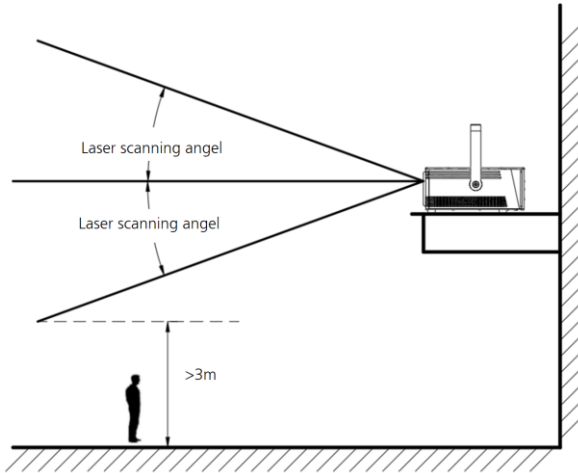

### 2. Insert Micro SD card

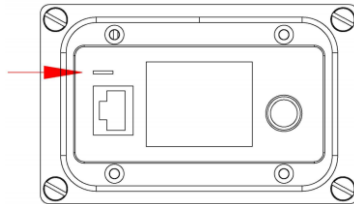

### 3. Open the laser aperture shield

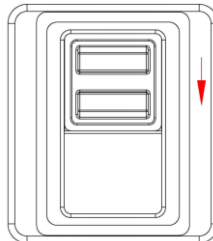

4. Install E-stopper or E-STOP terminator (if not install E-stopper for remote control) to the REMOTE IN.

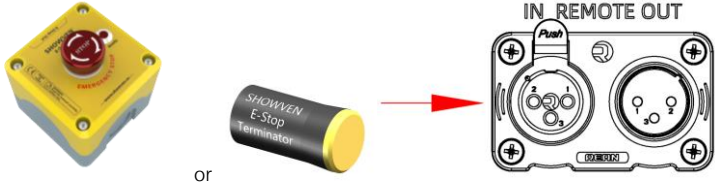

Maiman series with remote E-stop functions by connect E-STOPPER with REMOTE IN, and several units of lasers can be connected in series to be controlled by a single E-STOPPER as below.

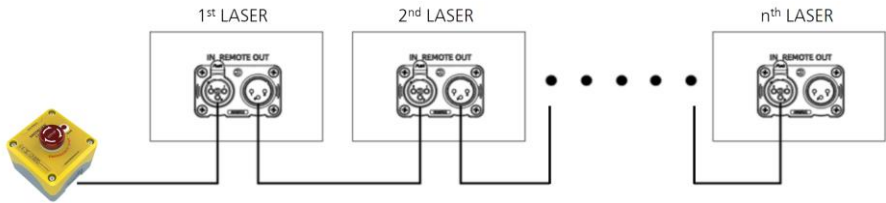

5. Connect Ethernet cable to ETHERNET IN.

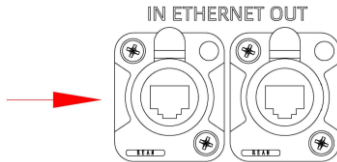

6. Connect with power cable, make sure power supply is consistent with the rated voltage of the equipment AC100-240V, 50/60Hz.

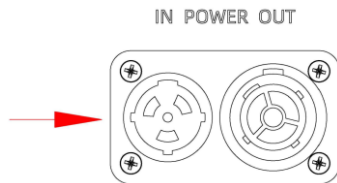

7. Switch on the POWER SWITCH

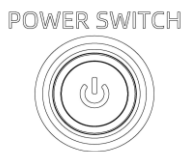

8. Switch safety lock to ON status, please double check it is safe to play the laser.



9. Operation with QuickShow, Beyond etc software. Please follow FB4 operation in this manual or FB4 operation manual from Pangolin.

10. Turn off laser output on software

11. Switch safety lock to OFF status



12. Switch OFF power switch, and pack the device.

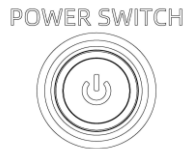

## Δ FB4 Operation

**Most of information in this part are from FB4 operation manual, you can also read FB4 operation manual directly for more detailed information.**

The FB4 has various operation modes. These operation modes determine which functions the FB4 will perform. Operation modes are explained below, however it's important to know when the FB4 stores settings and what will happen after a power failure or power cycle.

When starting up the FB4 the first time, the default [Operation Mode] is [BEYOND/QS]. Once you change the [Operation Mode] of the FB4, the FB4 will store this change after two seconds of inactivity. The new settings will directly become the new default and will stay active, even after a power cycle.

BEYOND/QS
▶ Exit Menu
Operation Mode
Master Settings
Color Settings

**[BEYOND/QS]**

In operation mode [BEYOND/QS], Pangolin's QuickShow and BEYOND software platforms are able to connect to the FB4 and control these directly through an ethernet network. To modify settings or change operating modes, you can use the control knob in conjunction with the LCD display. SHOWVEN Maiman series laser with three connection mode.

**1. Direct connection between computer and a single unit of Maiman Laser**

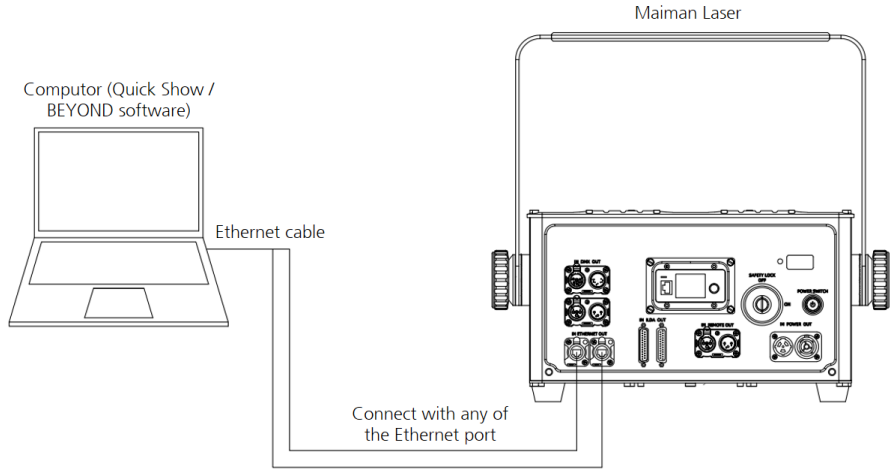

**NOTE:**

*The Ethernet port on FB4 is invalid, there is no signal input to this port. The connection method shown in the following picture is wrong*

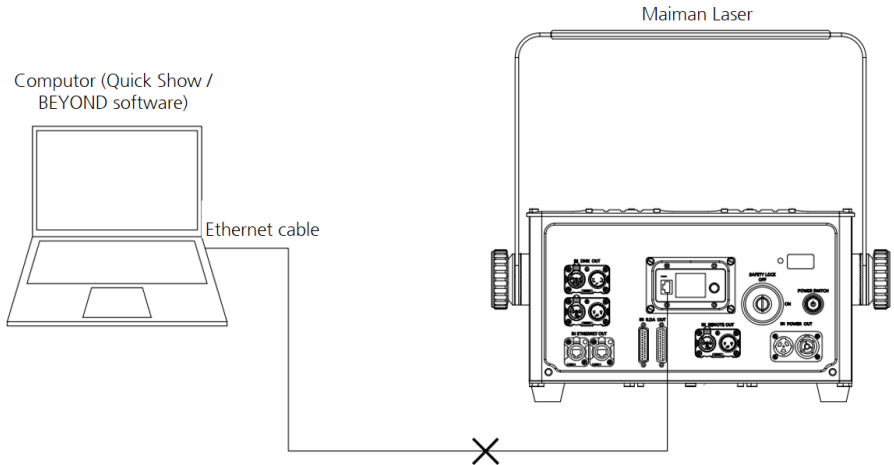

## 2. Connect computer and multi units of Maiman Lasers in series / daisy chain

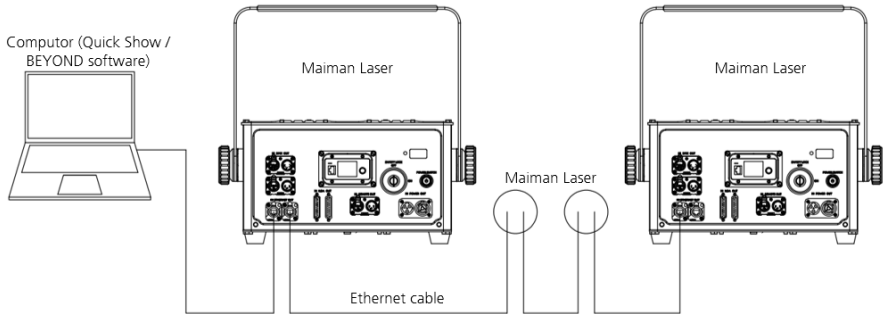

## 3. Connect computer with multi units of Maiman Lasers through switch

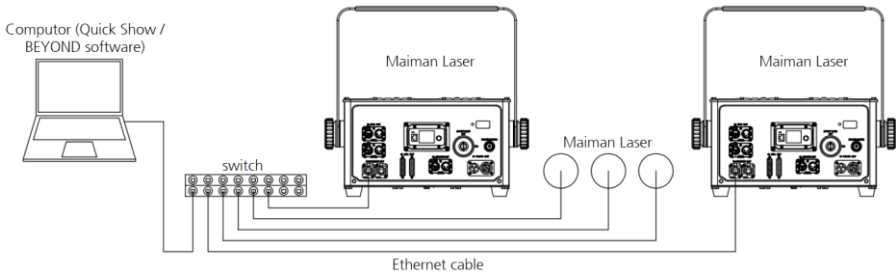

### **NOTE:**

*It is recommended to connect multiple laser in series via Ethernet port. DB25 interface series connection may cause FB4 signal conflict and image distortion.*

### **[DMX 512]**

Maiman series laser equipped with both 3-pin DMX IN/OUT and 5-pin DMX IN/OUT for DMX in and through. The DMX ports are meant to control the laser as "DMX fixture". Laser frames can be stored on the SD card and playback can be controlled by DMX. Laser frames can be uploaded by Pangolin's QuickShow or BEYOND its FB4 Export wizard through an ethernet connection.

### **NOTE:**

*DMX ports cannot be used to generate DMX output.*

*It is not possible to send content from QuickShow or BEYOND through the XLR cables connections.*

### **[Artnet]**

Artnet mode provides you access to the FB4's fixture profile by DMX over ethernet. The FB4 can be controlled by two separate fixture profiles. A 16-channel and a 39-channel fixture profile. As soon as the laser is being controlled through DMX, Content that is stored on the SD card of the FB4 can be played, limited by the functionality of the fixture profiles.

### **[Auto Play]**

The Autoplay mode allows one or more lasers to start and play content at specific predefined times or when the power of the laser is turned on. Autoplay requires that content is prepared through the FB4 export Utility inside QuickShow or BEYOND. This wizard will also allow you to schedule the shows that are stored on the SD card. Preparing content for automatic playback requires an ethernet connection with QuickShow or BEYOND. The actual playback does not require any cable connection.

### [Slave Mode]

[Autoplay] allows for scheduling shows across multiple projectors. When setting up a show which uses multi FB4's, one laser will need to act as master. This laser will need to be set in operational mode [Autoplay]. Other FB4's that need to perform in the same show, must be placed in operation mode [Slave mode] so that they will follow the master FB4.

For the master/slave functionality to work, all FB4's need to be connected to the same ethernet network.

### Slave Mode via DMX 512

Master setting: [Main Menu] – [Set up] – [Scan master/slave] – set it to ON, this laser is master.

Slave setting: [Main Menu] – [Set up] – [Scan master/slave] – set it to OFF (default setting is OFF), this laser is slave.

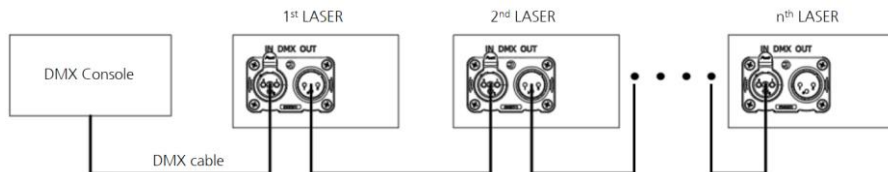

### [Time Code]

The [Time code] mode allows you to start the FB4 to play based on an incoming Artnet Time code signal (ATC for short). The content that will be played, will need to be prepared through QuickShow or BEYOND. This requires an ethernet connection.

### [ILDA Mode]

The ILDA mode menu option will only become available when an ILDA daughterboard is connected to the FB4. ILDA mode allows you to connect an ILDA cable from another controller. The ILDA daughter board support ILDA in and Through.

### [Test Mode]

The [test mode] has been created to give you the ability to open up a test frame without the need to connect other equipment. Test frames will need to be prepared and uploaded through Pangolin's QuickShow or BEYOND its FB4 Export Utility. During preparation of the test frames an ethernet cable is required. Once the test frames are located on the SD card of the FB4, there is no cable connection needed to activate [test mode].

## Δ SD Card

The system only accepts FAT32 files, and the new SD card needs to be formatted to FAT32 type before use.

For short file/folder names, the file name is limited to 8 characters, and the extended name is limited to 3 characters. The name can only contain English letters, Arabic numerals, and underscores. Others cannot be recognized.

Equipped with a device-specific SD card, no other files are saved inside; the number of folders is limited to 20, and each folder can only contain a maximum of 256 ILD files and 10 PRG files.

PRG playlist: Users can edit the playlist through a text editor. The playlist name is .PRG format. The playlist consists of file name, playback speed and playback time. "i" is the identification code of i Show, and the comma "," is used to separate it.

Only edit one program per line; for example, if a program PRG1.PRG contains 3 files: file1.ILD, file2.ILD, and file3.ILD; the playback speed of file 1. ILD is 12K, repeated 3 times; playback speed of file 2. The ILD is 20k, played once, file 2 is generated by i Show; the playback speed of file 3. ILD is 18K, repeated 4 times; the contents of PRG1.PRG are as follows:

```
File1.ILD,12,3  
File2.ILD,20,1
```

File3.ILD,18,4

After creating the folder, create a PRG file with the file name in the same folder, and edit all playback files to this PRG file. The editing speed here is the playback speed in ILDA mode. For example, create the folder "Laser show" and create the file "Laser show.PRG" under this folder; after adding a new ILDA file, we need to add this ILDA file to the PRG playlist so that we can ILDA mode correctly finds this file and plays it at the desired speed.

## Δ DMX Channels

Fixture mode FB3 – 16 channel DMX

Below the layout of the 16-channel fixture profile. The 16 and 32 channel fixture profile are not available at the same time.

Channels	Value	Description	Width
1	0-255 DMX Modes	0-31 Blackout / Safe 33-95 Four channels 97-159 Eight channels 161-232 Twelve channels 225-255 Sixteen channels	8 Bit
2	0-255 Page index (9 pages in total)	0-15 Page 1 17-31 Page 2 33-47 Page 3 49-63 Page 4 65-79 Page 5 81-95 Page 6 97-111 Page 7 113-127 Page 8 129-255 Page 9	8 Bit
3	0-255 Cue Index (48 cues in total)	0-32 None active 33-35 Cue 1 37-39 Cue 2 ... 221-223 Cue 48 225-255 Repeat	8 Bit
4*	0-255 Cue speed	0-15 Full speed 17-31 Pause 33-255 25 till 200%	8 Bit
5	0-255 Dimmer	0 till 100%	8 Bit
6	0-255 Zoom	0 till 100%	8 Bit
7	0-255 Size X	-100 till 100%	8 Bit
8	0-255 Size Y	-100 till 100%	8 Bit
9	0-255 Angel Z	0 till 360 degrees	8 Bit
10	0-255 Position X	0 = Left, 128 = Center, 255 = Right	8 Bit
11	0-255 Position Y	0 = Top, 128 = Center, 255 = Bottom	8 Bit
12	0-255 Visible points	Zero points till 100% of points visible	8 Bit
13**	0-255 Scan Rare	0-31 Cue speed 33-223 6K till 29K 225-255 30K	8 Bit
14	0-255 Cue release	0-31 Default 33-95 Hold 97-159 Loop	8 Bit



		161-223 225-255	Next Stop	
15	0-255 Color Scroll	0-31 33-223 225-255	Original cue color Color Scroll White	8 Bit
16	Reserved	Reserved		8 Bit

\* If a BPM based effects is exported at 100BPM, and you want to have a cue running on 128 BPM, change the speed to 128.

\*\* Lowering the scan rate can impact the cue speed of the laser

## Δ QuickShow / FB4 settings

### Scan rate setting

Please pay special attention to the setting of galvanometer frequency in QuickShow or other related software. The set frequency must be lower than the nominated maximum frequency of the galvanometer, otherwise it will cause damage to the galvanometer.

Take Maiman 30 setting in QuickShow 5.5 software as an example. Click the "Settings" menu at the top of the software, select "Projector settings", and the frequency setting interface pops up.

1. Connect to FB4;
2. Set the maximum frequency value of the galvanometer (35000);
3. Set default sample rate (PPS), for Maiman 30 we suggest to set it 30000, little bit lower than maximum frequency.

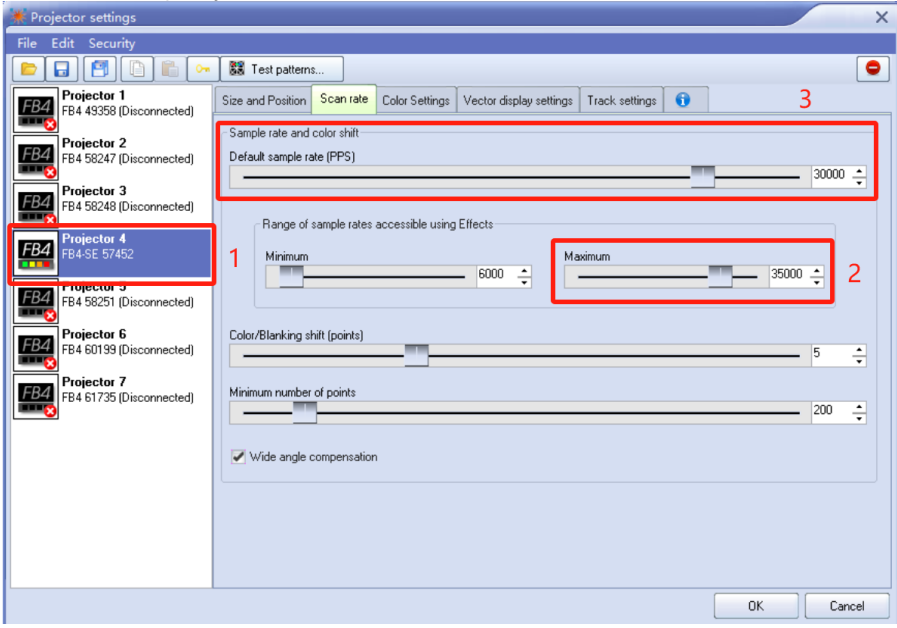

Maiman models and related scan rate setting value

Items	Maiman 30	Maiman 40	Maiman 60
Maximum scan rate	<35000	<30000	<25000
Default sample rate (pps)	≤30000	≤25000	≤20000

### Size and Position setting

Set the size X and Y to 80.

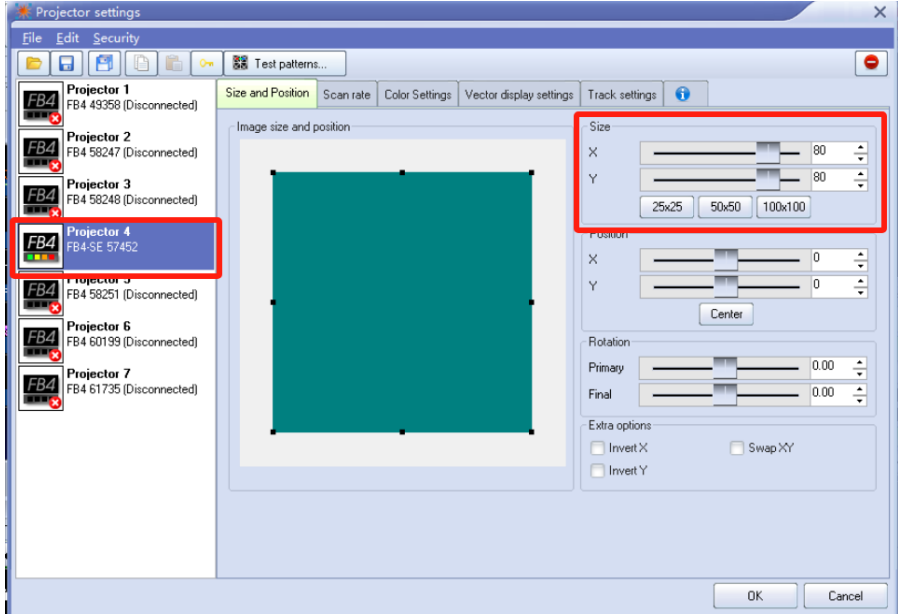

### Master setting

Set the master size  $\leq 80$ .



### **VERY IMPORTANT NOTICE:**

*Please set the parameters strictly according to the above parameters, otherwise the galvanometer may be damaged!*

## ▲ Beam Alignment

Beam Alignment only allowed to be performed by professional authorized technicians. Please read the following information carefully and take your time to process them! If you are not 100% certain that you understand the beam alignment principle, DO NOT ATTEMPT to proceed with the beam alignment by yourself.

The combination of laser from R, G, and B module can be misaligned due to many external factors, such as the laser falling, vibration during transportation, long use time, etc. The beam alignment is a process of pointing the beams coming out of laser modules inside your laser projector to the exact spot outside of the projector. If the colours are separated, the alignment must be made to ensure that all the mixed-colour projections are sharp and unified.

Beam Alignment environment request: humidity <50%; clean and no dust, the projection distance should be 6m at least.

Operation steps:

1. Wear laser goggles (specifications: optical density OD5 and above, protection band: 400nm~700nm)
2. Power OFF laser and disconnect power connection.
3. Open the alignment service cover at the side panel
4. Power ON the device. Open the laser light test TOP picture in FB4. If RGB three colors do not overlap, you need to adjust the light until the red, green and blue lights are adjusted to overlap. The principle of alignment is to fix a certain light source and adjust the other two light sources so that the three colors of light overlap.
5. Position 1 in beam alignment hole adjusts the up and down position of the light spot, and position 2 adjusts the left and right position of the light spot.

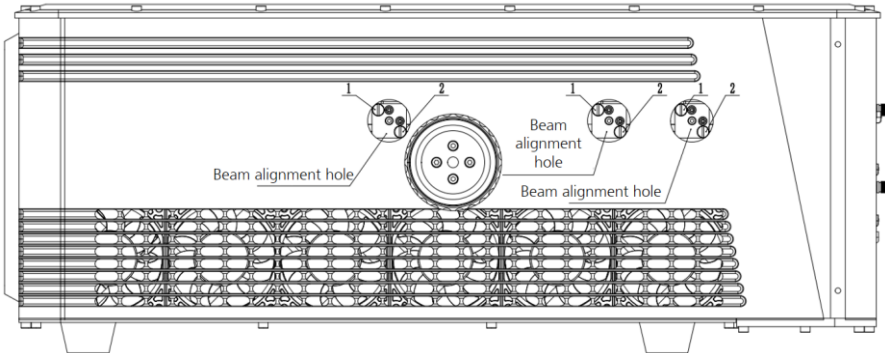

### NOTE:

Above picture is just a schematic diagram of the beam alignment port position. The relative position on each model (Maiman 30/40/60) will be slightly different. If you have any questions, please contact us.

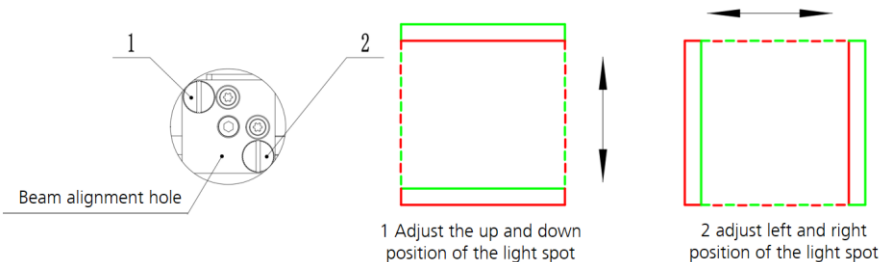

## Δ **Trouble Shooting**

Q: Laser projector doesn't work or no laser output.

- A: 1. Check whether the power cable is well connected, check whether fuse is burned out.  
2. Check power supply in consistent with the rated voltage of the equipment.  
3. Check whether safety lock switched to ON status.

Q: Laser projector can't be controlled by sound.

- A: 1. Check whether the display buttons are set to sound control mode.  
2. The sound control sensitivity value is too small. Select a larger sound control sensitivity value.

Q: Normal laser output but lost control by FB4.

- A: 1. Make sure the hardware is under mode [BEYOND/QS]  
2. Make sure [Auto IP] is enabled in [Network Setup].

Q: Laser output flashes under [DMX 512]/[Art net] mode.

- A: Please adjust the [DMX 512]/[Art net][time out] settings

Q: Master-slave synchronization mode, the master is normal and the slave is abnormal.

- A: 1. Confirm that there is only one master laser, no DMX console connected to the master, and it is set to sound control or auto mode.  
2. If master and slave setting are correct, please check the cables

Q: The laser output is dim and the brightness drops significantly

- A: 1. Check whether the LD is reached it's life expectancy.  
2. Check whether the internal and external optical systems are clean.

## Δ **Maintenance**

### **Laser aperture window cleaning:**

Use medical cotton swabs and absolute ethanol to clean the lenses and clean the light exit glass.

### **Cooling fan cleaning:**

The cooling fan plays a vital role in the normal operation of the equipment. Please clean the air inlet of laser regularly. When the equipment is used frequently, the fan should be cleaned once every month, or in an environment with dust and oily smoke, the cleaning frequency should be increased. The actual operation should be carried out according to the environment in which the equipment is used to ensure the normal operation of the fan.

### **Internal optical cleaning:**

Cleaning internal optical components requires professional and authorized technicians. Improper cleaning techniques or poor cleaning choices can cause serious damage to equipment. Since the optics are separate and sealed from the rest of the light source system, this should not be done more than once a year.

## Δ Packing List and Optional Parts List

Item No.	Description	pcs / unit	Remark
1	Micro SD card	1	Standard
2	E-STOP terminator	1	Standard
3	Power cable	1	Standard
4	Ethernet cable	1	Optional
5	5-pin DMX cable	1	Optional
6	3-pin DMX cable	1	Optional
7	E-STOPPER	1	Optional
8	Safety rope	2	Optional
9	Clamp	2	Optional

Items with remark of "Standard" means it is a standard configuration contains in the package, "optional" parts please order it separately if needed.

## Δ **Warranty Instructions**

- \ Sincere thanks for your choosing our products, you will receive quality service from us
- \ The product warranty period is one year. If there are any quality problems within 7 days after shipping out from our factory, we can exchange a brand new same model machine for you
- \ We will offer free of charge maintenance service for machines which with hardware malfunction (except for the instrument damage caused by human factors) in warranty period. Please don't repair machine without factory permission

### **Below situations NOT included in warranty service:**

- \ Damage caused by improper transportation, usage, management, and maintenance, or damage caused by human factors;
- \ Disassemble, modify or repair products without permission;
- \ Damage caused by external reasons (lightning strike, power supply etc.)
- \ Damage caused by improper installation or use;

For product damage not included in warranty range, we can provide paid service. Invoice is necessary when applying for maintenance service from SHOWVEN®.



# SHOWVEN<sup>®</sup>



**Showven Technologies Co., Ltd.**

Tel: +86-731-83833068

Web: [www.showven.cn](http://www.showven.cn) E-mail: [info@showven.cn](mailto:info@showven.cn)

Add: No.1 Tengda Road, Liuyang Economic & Technical Development Zone, Changsha,  
Hunan, 410300, P.R.China