

# USER MANUAL

## uFlamer Max

V1.2  
2024/11/12

**SHOWVEN®**



**SHOWVEN Technologies Co., Ltd**

Thanks for choosing SHOWVEN uFlamer Max, we wish it will bring you lots of exciting moments. Please read the following user's manual and related product installation guide carefully before operating this device.

## **△ Safety Instructions**

### **1. Safety icons explanation**

Safety instructions warn of hazards when handling equipment and provide information on how to avoid those hazards. They are classified according to the severity of the hazard and are divided into the following groups. Please do follow all safety instructions in this document!

**DANGER:** Indicates a hazardous situation that, if not avoided, will result in death or serious injury. (This signal word is limited to the most extreme situations)

**WARNING:** Indicates a hazardous situation that, if not avoided, could result in serious injury

**CAUTION:** Indicates a hazardous situation that, if not avoided, could result in minor or moderate injury.

**NOTICE:** Provide additional or supplementary information.

### **2. General Safety Instructions**

- ∨ Unauthorized repair are prohibited, it may cause serious incident.
- ∨ Make sure power supply is consistent with the rated voltage of the equipment, and the socket must be well grounded. Unplug and turn off the machine when not in use.
- ∨ Please connect DMX cable before power on uFlamer Max, and ensure that the communication command is disabled, and the safety switch of the device is under test mode.
- ∨ After turning on the device, no person is allowed to stay in the danger area. Ensure all persons that are part of the show are informed about the safety distance, risks and functions of the device.
- ∨ Always have a CO<sub>2</sub> fire extinguisher and an extinguishing blanket in case of need.
- ∨ If there is any doubt as to the safety operation of the device in any circumstances, the device should be taken out of service immediately. Be sure the device is in good operating condition before use. If it fails to fire correctly, immediately shut down and check it accordingly. Any questions please always contact SHOWVEN (info@showven.cn) for help.
- ∨ Be sure to use high quality fuels, otherwise, it easily leads to failure or danger. Please keep fuels away from heat source, sparks, fire or other possibility of ignition. Do not smoke!
- ∨ The operator responsible for the control of the flame system must always have a clear view of the device, so that he/she can stop the show immediately when there is danger. The main AC power switch should be near the operator. So that the operator can turn off the power of all devices in case of abnormal.
- ∨ The device shall not be altered and applied to other use purposes.

### **3. Disclaimers:**

SHOWVEN technologies Co., Ltd excludes liability for unsafe situations, accidents and damages resulting from:

1. Ignoring warnings or regulations as shown on product manual or this manual.
2. Use for other applications or circumstances other than those indicated herein.
3. Changes to the device, including use of non-original spare parts, lack of maintenance etc.
4. Dismantling device without authorization from SHOWVEN.
5. Use of this machine by unqualified or untrained personnel.
6. Improper use of machine.

## **Warning:**

A dry powder fire extinguisher, a carbon dioxide fire extinguisher and a fire blanket must be equipped next to the equipment. Someone must be on duty during operation. In case of fire accident, dry powder fire extinguisher can be used when the fire is large, and a carbon dioxide fire extinguisher can be used when the fire is small.

## **▲ Technical Specifications**

- \\ **Model:** uFlamer Max
- \\ **Housing Material:** 304 stainless steel
- \\ **Dimension:** 570×425×380mm
- \\ **Weight:** 60kg
- \\ **Input:** AC200-240V, 50/60Hz
- \\ **Work Power:** 2.5KW
- \\ **Usage in Rain:** Yes
- \\ **Ignition:** Triple, high voltage electron ignition, auxiliary ignition
- \\ **Flame Monitoring:** Yes
- \\ **Control:** DMX , 9-60V pyro signal, Wireless with Wireless DMX Receiver (5-PIN DMX IN with DC5V power supply)
- \\ **DMX:** 3-pin and 5-pin DMX IN / OUT
- \\ **E-Stop Interface:** Yes, can be connected in series
- \\ **Effect Direction:** Vertical
- \\ **Flame Height:** up to 20m
- \\ **Max. Firing Duration:** 0.5s
- \\ **Tank Capacity:** 17L
- \\ **Fuel:** ISOPAR L/M
- \\ **Liquid Level Sensor:** Yes
- \\ **Fuel Tube Filter:** Yes
- \\ **Tip sensor:** Yes

## ▲ Structure

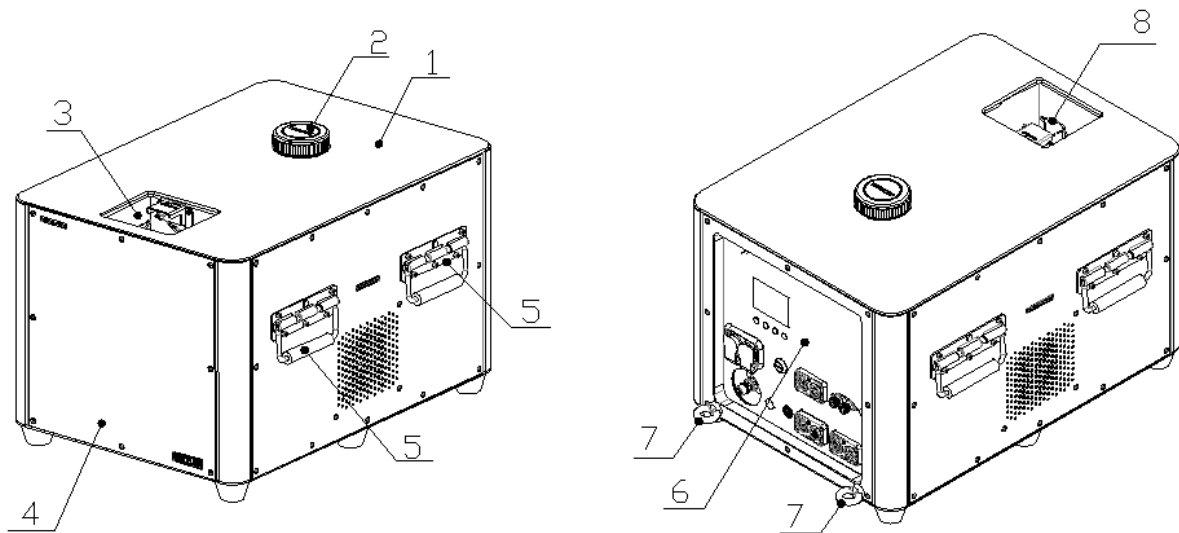

1. Top panel
2. Fuel tank lid
3. Fire box
4. Front panel
5. Handle
6. Rear panel
7. Safety loop (optional)
8. Igniter (triple)

### Diagram of bottom panel

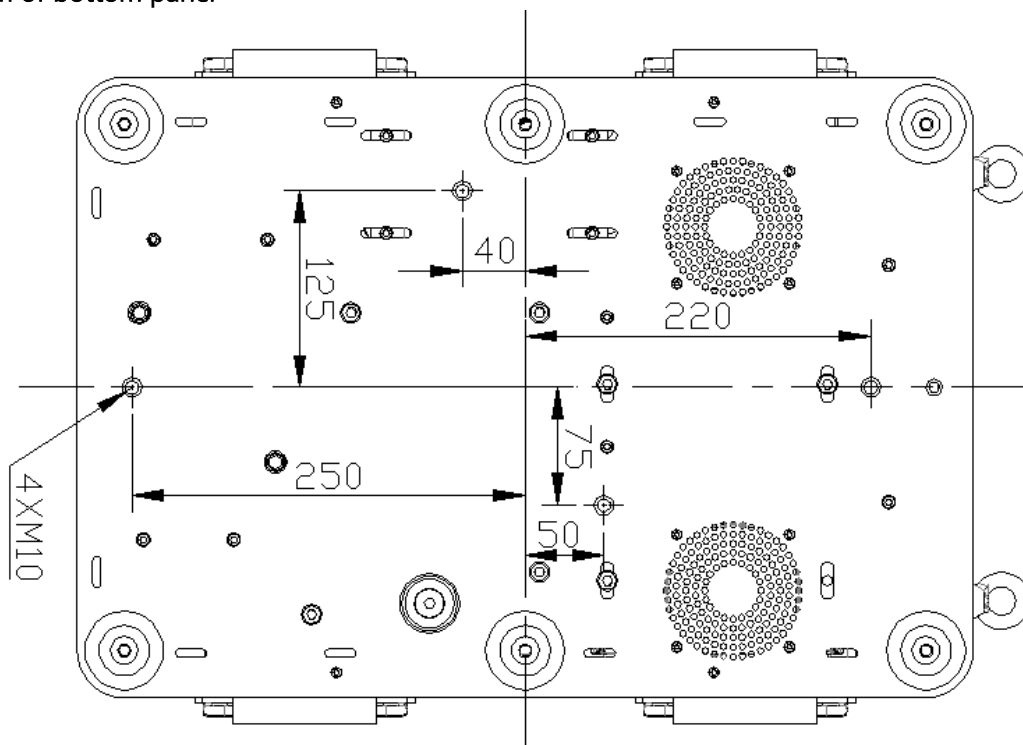

## ▲ Rear Panel

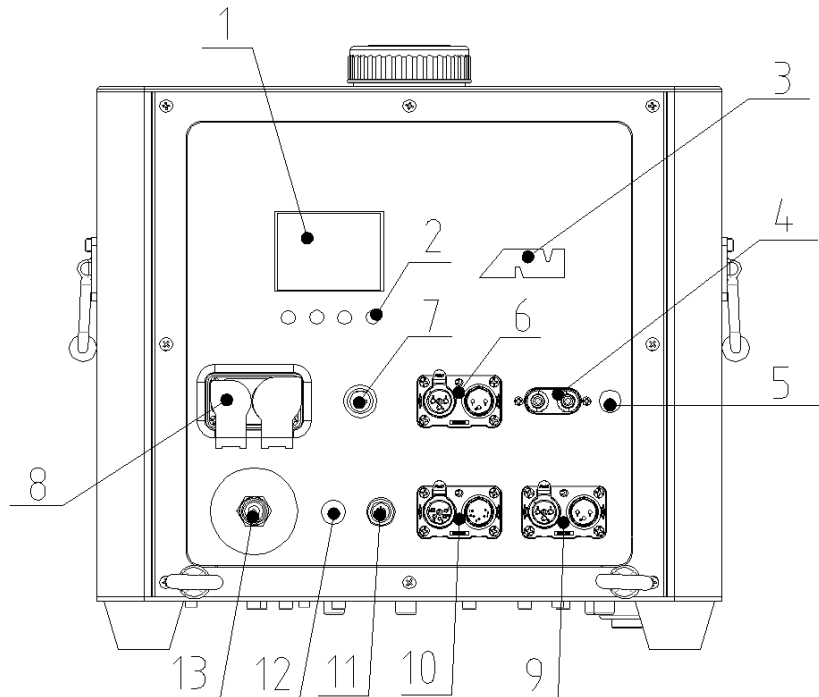

1. LCD screen
2. Touch button
3. ARM indicator light
4. 9-60V pyro signal port
5. DC12V external fuel pump power supply
6. 3-pin XLR IN/OUT
7. Safety switch
8. Power IN / OUT
9. E-stop interface
10. 5-pin XLR IN/OUT (5-PIN XLR IN can charge for wireless DMX pen through pin1 and 4, pin4 with DC5V power supply)
11. Power Switch (with Power indicator light)
12. Fuse
13. External fuel in quick coupler (ISO7241B quick coupler G1/4 Male)

## ▲ Display and setting

### 1. Welcome interface

Software Version	FA30-240419
Serial Number	*****
Pump Run Time	00:00:00
Ignition Times	xx

## 2. Main interface

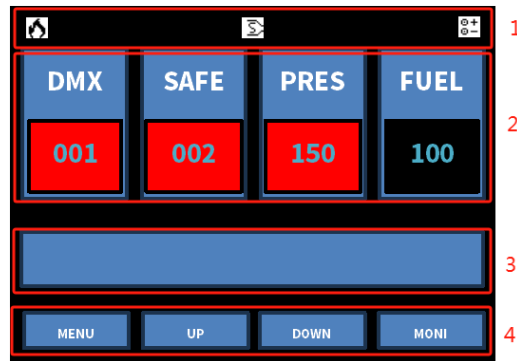

1.) Three icons may appear in the status bar 1



: appears when "Flame Monitor" is "ON"



: appears when "Flame Monitor" is "ON" and detected successful ignition



: appears when "External Trigger" is "ON"

- 2.) **DMX:** DMX address, Background turns from BLACK to RED when DMX cable was connected.  
**SAFE:** Safety address, Background turns from BLACK to RED when DMX cable was connected and safety channel activated.  
**PRES:** Pressure value. Background turns from BLACK to RED when pressure exceed "set low pressure".  
**FUEL:** Fuel level indicate. Background turns from BLACK to RED when actual fuel level  $\geq$  "Fuel Level Alarm" setting in ADVANCED MENU.
- 3.) USER MODE / error or alert information display, Background color turns to RED when under "USER MODE".
- 4.) Touch Button function display:  
**First Button:** MENU / BACK  
**Second Button:** UP / LEFT  
**Third Button:** DOWN / RIGHT  
**Fourth Button:** MONI / EDIT / SAVE

Note: screen display will switch to main interface if there is no operation in 10s.

## 3. ARM indicator light



Operators can enable/disable the arm indicator light by set the "ARM STATE" in ADVANCED menu. If "ARM STATE" is ON, there will be three status:

**OFF:** DMX signal input

**BLINK:** DMX armed or Ext Ignite in advanced menu is ON

**ON:** no DMX signal and Ext Ignite in advanced menu is OFF

## 4. Alert Message

Alert Message	Why it appears	How to remove
E0 Test Mode	Safety Key Switch at TEST MODE	Switch Key to USER MODE
E0 Factory Mode	Factory mode	Switch to Normal mode
E0 ExtIgnite ON	"External Trigger" is "ON"	Set "External Trigger" to "OFF" in Advanced menu
E0 Ignition Disable	"Ignition" is "Disable"	Set "Ignition" to "Enable" in Factory menu
E0 Key Lock	Touch button no operation in 30s	Restart machine

## 5. Error Message

Error Message	Why it appears	How to remove
E1 Pressure Err	Consecutive pressurize failure times exceed "Pressure Fail Cnt" setting value	Restart machine or reset safety channel
E2 P Relief Err	Pressure keep above 10 after pressure relief	Restart machine
E3 DC Err	Voltage abnormal	Power supply module abnormal, please check accordingly.
E4 MissFire Exceed	Consecutive ignition failures exceed the set value of "Fl Moni Fail Num" in advanced interface	Restart machine / reset safety channel / set "Flame Monitor" to OFF
E5 Press Sensor	Pressure Sensor loosen or damage	Check pressure sensor
E6 Fuel Low	Actual "Fuel Level" < set value of "Fuel Level Alarm" in ADVANCED MENU	Fill the tank
E7 Tip Err	Machine slant over 45°, it stops running	Tip setting set to OFF, or horizontal install machine.

## 6. Monitoring Interface

Press "MONI" enter below interface

Menu	Explanation
Pressure	Current pressure value
Fuel Level	Current fuel level
User Mode	<15V is under test mode
Igniter Voltage	Flame monitoring value display
Motor Speed	Motor running speed display
DC voltage	DC power supply voltage
Pump Run Time	Accumulative pump working time
Ignition Times	Accumulative ignition times

## 7. Menu Interface

Press "MENU" enter below interface

Menu	Explanation
MAIN	Main menu
ADVANCED	Advanced menu
TEST	Test menu
FACTORY	Factory menu (factory use only)

## 8. Main menu

Select "MAIN" in menu interface, press "EDIT" enter main menu. Use UP / DOWN / SAVE to change the parameters.

Menu	Range	Default	Explanation
Set DMX Address	1~512	1	DMX address setup
DMX Mode Select	2CH-N/2CH-P/6CH-N	2CH-P	DMX mode setup
Set Safety Address	1-512	2	Safety address setting under 2CH-P mode
Safety Level	76-120/ 102-153/ 127-178/ 153-204/ 178-229	102-153	Available only under 2CH-P mode. Safety channel DMX value within the set threshold range, firing enabled; outside the range, firing disabled.

## 9. Advanced menu

Select "ADVANCED" in menu interface, press "EDIT" enter advanced menu. Use UP / DOWN / SAVE to change the parameters.

Items	Contents	Default	Description
External Trigger	OFF / ON	OFF	Trigger through 9-60V pyro ignition signal
External Time	0.2s~0.5s	0.2s	Firing duration under external trigger, this menu appears only when Ext Ignite is ON.
Tip Setting	OFF / ON	ON	Turn ON/OFF tip over function
Fuel Alarm Switch	OFF / ON	ON	Turn ON/OFF low level alarm function
Fuel Level Alarm	0-100%	5%	Machine will alarm and stop working when fuel level lower than setting value
Fuel Input	ON / OFF	OFF	Automatic filling tank when fuel level low
PV ON FuelLevel	0-100%	20%	Automatic filling start when fuel level lower than this setting value. (Fuel Input ON status)
PV OFF FuelLevel	0-100%	90%	Automatic filling stop when fuel level exceed this setting value. (Fuel Input ON status)
PV EMER OPEN	OFF / ON	OFF	If set ON, Fuel Input valve will open 3s then close
Flame Monitor	ON/OFF	OFF	Check the firing was success or not
Fl Moni Value	0.01V-3.30V	0.32V	Threshold value for a successful firing
Fl Moni Fai Num	0-10	2	Consecutive ignition failures setting, if ignition fail times > setting value, machine will report error.
Key Sound	ON/OFF	ON	Touch button sound ON / OFF
ARM State	ON/OFF	ON	ARM indicator light ON/OFF setting
LCD Backlight	ON/OFF	OFF	LCD backlight ON/OFF. When ON, screen will flash when firing; OFF: LCD screen will turn off when no operation.
Key Lock	ON/OFF	OFF	ON: Touch button will disable if there is no operation in 30s. restart machine to active touch button.
DefaultParamete	ON/OFF	OFF	Reset default parameter settings

## 10. Test menu

Please disconnect DMX connection before enter test menu.

Select "TEST" in menu interface, press "EDIT" enter test menu. Use UP / DOWN / SAVE to change the parameters.

"External Trigger" will disable after enter TEST menu, Pressure relief valve will open, below related items will shows Running when testing, shows Finish after test finished.

Items	Description
ARM Test	Test ARM indicator light, blink once/s, blink 3 times
Jet Valve Test	Jet valve ON/OFF 3 times, 1s per time
Relief Test	Relief valve ON/OFF 3 times, 1s per time
Switch Valve Test	Switch valve ON/OFF 3 times, 1s per time
DC12V Output Test	DC12V output test, ON/OFF 3 times, 1s per time
Fuel Valve Test	Fuel Valve ON/OFF 3 times, 1s per time
Igniter 1 Test	Igniter 1 ON/OFF 3 times, 1s per time
Igniter 2 Test	Igniter 2 ON/OFF 3 times, 1s per time
Igniter 3 Test	Igniter 3 ON/OFF 3 times, 1s per time
Pump Test	Pump will pressurize to "Set Pressure" value and keep 2s, and display "F". If pressurize time exceed setting value of "Max Pressure Limit", means pump test fail, it will display "E". Display "R" means machine is pressurizing.



## ▲ DMX CONTROL

uFlamer Max with 3 different channel mode: 2CH-P, 2CH-N and 6CH.

### 2CH-P:

In this channel mode uFlamer Max occupies 1 functional channel CH-F and 1 separate safety channel CH-S (this channel is independent from operational channel, can be shared with other machine).

Channel	Function	Value
CH-F	Firing	0~110: Firing OFF 111~255: Firing ON
CH-S	Device enable / disable	0~101 and 154~255: Depressurize mode, disable device (Emergency STOP) 102~153: Pressurize mode, enable device Above setting is take the default safety level (102-153) setting as an example, other safety level value setting please refer to advanced interface

### 2CH-N:

In this channel mode uFlamer Max occupies 2 functional channels.

Channel	Function	Value
CH-1	Firing	0~110: Firing OFF 111~255: Firing ON
CH-2	Firing Enable / Disable	0~239: Firing Disable (Emergency STOP) 240~255: Firing Enable

### 6CH:

In this channel mode uFlamer Max occupies 6 functional channel. This channel mode is designed to control the uFlamer together with CIRCLE FLAMER on our Host Controller.

Channel	Function	Value
CH1	-	-
CH2	-	-
CH3	Firing ON/OFF	0~253: Firing OFF 254~255: Firing ON
CH4	Firing Duration setup	0 and 255: permanent fire (0.5s is limit duration time) 1~254: 10~2540ms duration time (Manual firing duration = DMX Value * 10ms)
CH5	-	-
CH6	Firing Enable / Disable	0~49 and 201~255: Firing Disable (Emergency STOP) 50~200: Firing Enable

## ▲ Operation

### 1. Safety distance explanation

Safety distance for uFlamer Max divided into two parts safety radius around machine (a) and safety distance at firing direction (b). No person and flammable materials are allowed to stay inside the safety isolation zone when flamer was armed.

The safety radius around machine with a radius of 5m.

For safety distance at firing direction equals to maximum firing height \* 1.5.

Max. Flame Height	Safety Radius (a)	Safety Distance at Firing Direction (b)
20m	5m	30m

The uFlamer Max safety isolation zone (show as below) is a cylindrical three-dimensional space with Safety radius around machine (a) and Height of b. Unauthorized persons and objects are strictly prohibited from entering.

For angled installation, the safety distance both around machine and firing direction should shift accordingly.

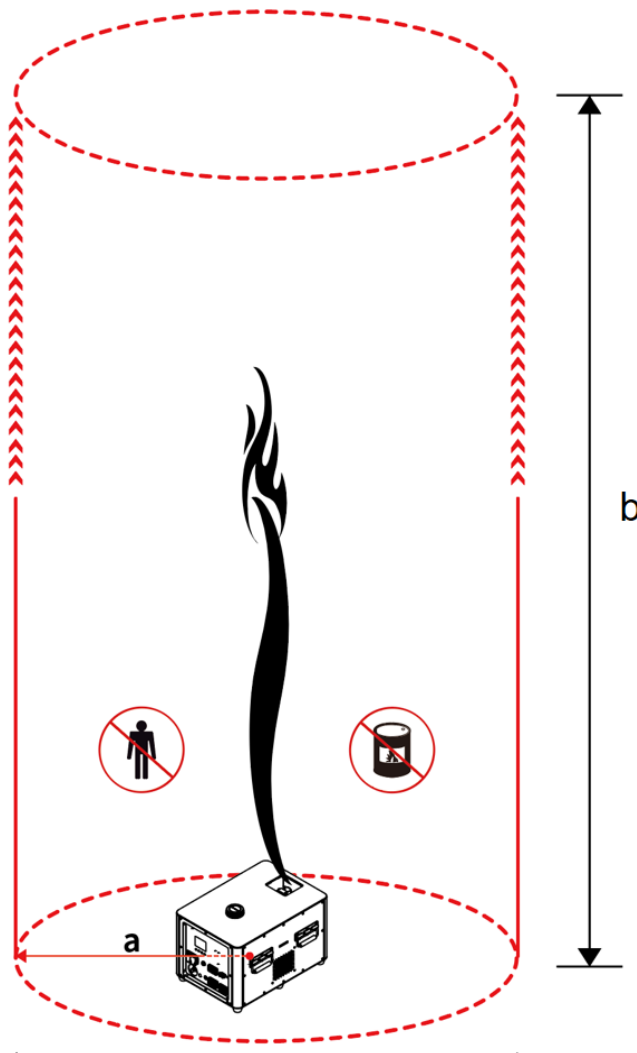

### Safety distance in windy environment

The safety isolation zone radius (a) increase with wind direction and wind speed (v, m/s). The safety distance in windy conditions can be calculated as below:  $a = 5 + v$ ;

For example when the wind speed is 3m/s, then the safety isolation zone radius should be 8m, When the wind speed  $\geq 8$ m/s (wind force  $\geq 5$ ), please use it with caution. When wind speed  $\geq 17$ m/s (wind force  $\geq 8$ ) , please stop use Flamer.

## 2. Install uFlamer Max

uFlamer Max can only be installed horizontally on firm surface as below. If install on truss please make sure it is firmly installed, also please do connect with qualified safety rope.

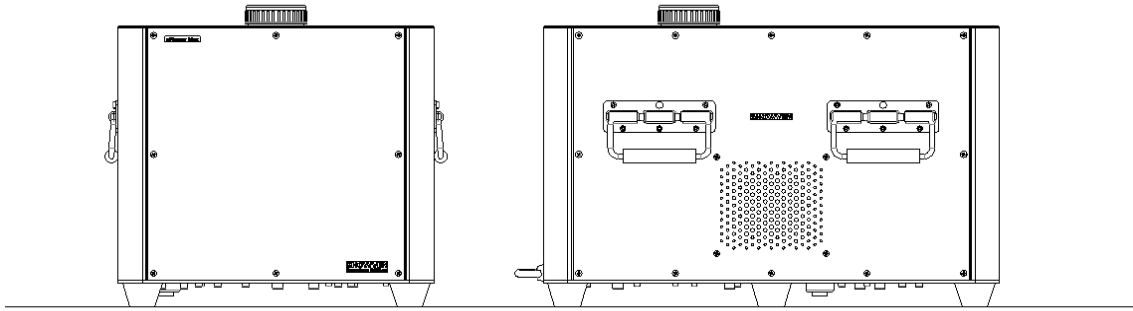

**WARNING:** Forbid to install uFlamer Max in tilt position.

## 3. Fuel the uFlamer Max

- Switch safety lock to TEST MODE.
- Fill the fuel tank with qualified fuel. To prevent the fuel from overflowing the tank please not exceed the upper limit (top of the yellow sponge).

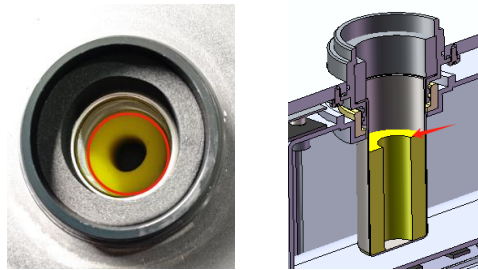

**WARNING:** Fuel requirements for uFlamer Max

- Water content in fuel should less than 0.5%
  - For maximum safety, please use fuel with flash point between 60-80°C, ISOPAR L or M is highly recommended.
  - Colored fuels are forbidden to use on uFlamer Max it may damage the machine.
- SHOWVEN excludes liability for the losses, damages and accidents caused by not using qualified fuels in accordance with this requirement.

## 4. Connecting uFlamer Max

Make sure the DMX or pyro controller is disarmed or powered off during cable connection.

**If control by DMX controller, follow below steps:**

- Connect a DMX cable to the DMX IN socket of first unit of uFlamer Max, another head of this DMX cable connect to DMX console (such as FXcommander). Make sure the DMX console is powered off.
- Connect a DMX cable to the DMX OUT socket of previous uFlamer Max, and the other end to the DMX IN of next machine. Connect all devices in series in this way.
- Suggest to plug in a DMX terminator into the DMX OUT in last unit of machine to improve signal reliability. For distance >200m please use SHOWVEN DMX splitter 8 to amplify the signal.
- Connect a power cable to the POWER IN socket of uFlamer Max. Make sure power supply in consistent with the rated voltage of the equipment, and the socket must well grounded.
- Connect machine with E-stop terminal or E-Stopper.

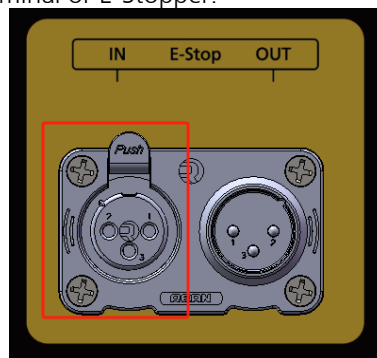

- f) Power on all uFlamer Max. Check the safety lock, double confirm it stays at "TEST MODE".
- g) Assign DMX address for each unit of uFlamer Max. If use SHOWVEN host controller or FXcommander to control the machine please allocate a unique DMX address for each unit of machine.

**If control by 9-60V pyro signal, follow below steps:**

- a) Connect a power cable to the POWER IN socket of uFlamer Max. Connect the other end of power cable to the power source. Make sure power supply is consistent with the rated voltage of the equipment, and the socket must well grounded.
- b) Connect the power control cables to the 9-60V pyro signal connector on uFlamer Max.
- c) Connect the other end of power control cables to the pyro controller (9-60V external trigger source), such as SHOWVEN PyroSlave series module.
- d) Connect machine with E-stop terminal or E-Stopper.
- e) Power on all uFlamer Max
- f) Set the Ext Ignite to ON status in advanced interface, set the firing duration.

**5. Power ON the DMX console/Pyro controller and programming**

Power on DMX console and program the uFlamer Max effect on DMX console  
 Firing intervals for uFlamer Max as below, please keep the minimum intervals when programming.

Firing Duration	0.2s	0.3s	0.4s	0.5s
Minimum Interval	3s	4s	5s	5s

Note: Minimum interval means the interval between firing, it is the time for pump to pressurize and restore the pressure to target firing pressure.  
**WARNING:** insufficient interval time, may leads to firing disable or firing failures due to the pressurization is not completed.

**6. Test the ignition function of uFlamer Max**

Test the ignition function of uFlamer, we can check whether the igniters of each unit of uFlamer is working fine. Due to the safety switch is stay at TEST MODE there will be only ignition while jet solenoid valve is not open, so no flames generated.

**7. Firing**

- a) Double confirm the prescribed safety isolation zone is clear, no person, animal or other property within this region.
- b) Switch the safety lock of uFlamer Max to USER MODE.

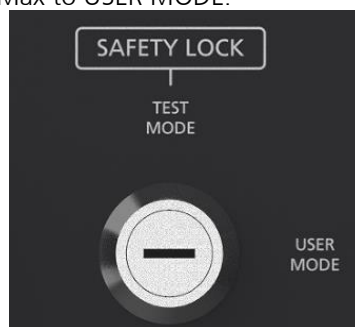

- c) Firing, the operator should always have a clear view of the device, so that he/she can stop the show immediately when there is danger.

**8. Depressurize and Power OFF**

- a) Depressurize the flame unit after show or not use flamer for a period of time
- b) Power OFF DMX console
- c) Press E-Stopper to power OFF all machine (if connect with E-stopper)
- d) Switch safety lock of uFlamer Max to TEST MODE
- e) Power OFF each unit of machine

**9. Empty the remaining fuels and package machine**

- a) Unplug power cable, DMX cable, E-Stopper connection cable etc.
- b) Suggest to empty the remaining fuels inside fuel tank before shipment and storage
- c) Package the machine when it is cool down

## ▲ Nozzle Replacement and Igniter Position Adjustment

### 1. Nozzle Replacement

Use 14mm outer hexagon socket wrench (SFMET944) to disassemble the nozzle, clean the nozzle and nozzle socket with air gun (air compressor), change a new nozzle and install it.

Mark 1 in below picture is NOZZLE XXH, it is the main nozzle for 20m flame effect. 2 is NOZZLE EL, is the auxiliary nozzle. Please be sure not to mix up the positions of these two nozzles.

### 2. Igniter Position Adjustment

Whenever changed the nozzle or ignition is not good, please check igniter pole position according to below parameters. The right position  $A=2.5-3\text{mm}$ ,  $B=18 \pm 1\text{mm}$ ,  $C=8 \pm 0.5\text{mm}$ . Check the ignition successful rate after adjustment by firing.

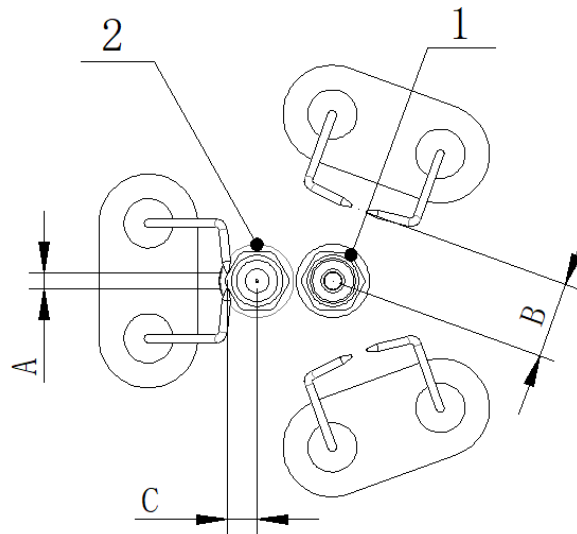

**WARNING:** Do unplug the power cable when service flamer.

## ▲ Maintenance

1. To maintain the machine in good performance and running status, it is recommended to running the device at least once per month.
2. Check the ignition probes both before and after each show, if there is any foreign objects on it please clean it up.
3. Maintenance of the nozzle: Nozzle needs to be cleaned from time to time, and it is recommended that once every six months (depending on the environment and frequency of use). In the process of using the equipment, if the flame shape is seriously deformed or the fuel injection line is significantly deformed or coarsened, the nozzle should be removed immediately for cleaning. If after clean, there are still problems please replace new nozzle.
4. Maintenance of the O-ring: If it is found that the O-ring of the nozzle is damaged or ageing when cleaning the nozzle, the O-ring should be replaced in time.
5. Flame detector maintenance: Recommended to clean the carbon buildup on flame detector at least once per month (depending on the use environment and frequency), if the detector is found to be insensitive, clean it immediately.
6. Emptying operation of the fuel tank

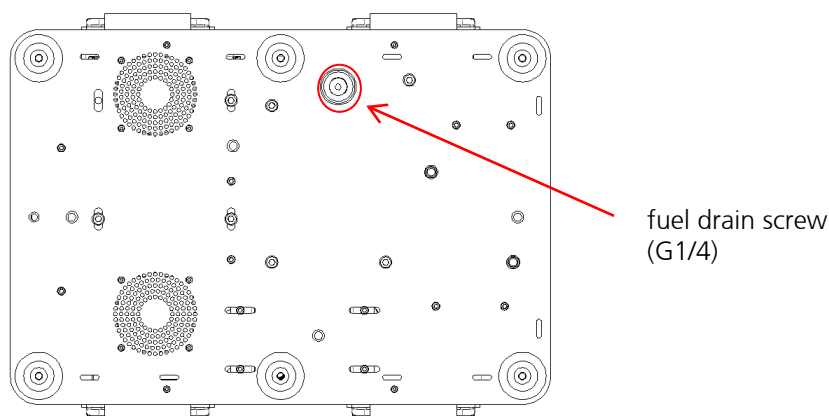

**WARNING:** Please pay attention to the tightening torque of the fuel drain screw. It should not exceed 10N\*m, otherwise, the fuel tank will be damaged. This operation is prohibited for non-professionals.

## ▲ Optional Parts for uFlamer Max

Part. No.	Description	pcs / unit
SFSMA029	NOZZLE XXH	1
SFSMA027	NOZZLE EL	1
RMSMA530	SS304 gasket, outer $\phi$ 18, inner $\phi$ 14, thickness 1.5mm	1
RMWAS025	Fluorine O ring, outer $\phi$ 14, line diameter is 2 mm	1
SFMET1107	G1-E-Stop connector	1
RMFLI001	Flightcase with Penn Elcom parts	1
RMMAT112	Transformer One-way 110V to One-way 220V, 3000W	1
SFMET944	Tool for exchange nozzle	

## **▲ Warranty Instructions**

- ∨ Sincere thanks for your choosing our products, you will receive quality service from us
- ∨ The product warranty period is one year. If there are any quality problems within 7 days after shipping out from our factory, we can exchange a brand new same model machine for you
- ∨ We will offer free of charge maintenance service for machines which with hardware malfunction (except for the instrument damage caused by human factors) in warranty period. Please don't repair machine without factory permission

### **Below situations NOT included in warranty service:**

- ∨ Damage caused by use unqualified fuels;
- ∨ Damage caused by improper transportation, usage, management, and maintenance, or damage caused by human factors;
- ∨ Disassemble, modify or repair products without permission;
- ∨ Damage caused by external reasons (lightning strike, power supply etc.)
- ∨ Damage caused by improper installation or use;

For product damage not included in warranty range, we can provide paid service.

Invoice is necessary when applying for maintenance service from SHOWVEN

# SHOWVEN<sup>®</sup>



**Showven Technologies Co., Ltd.**

Tel: +86-731-83833068

Web: [www.showven.cn](http://www.showven.cn) E-mail: [info@showven.cn](mailto:info@showven.cn)

Add: No.1 Tengda Road, Liuyang Economic & Technical Development Zone, Changsha, Hunan, 410300,  
P.R.China